

İlk Okuma-Yazma

1. Ses Grubu: E,L,A,K,I,N



I. Kademe (1. 2. 3 ve 4. Sınıf)
Ders Kitabı



İlk Okuma-Yazma

1. Ses Grubu: E,L,A,K,İ,N

I. Kademe (1, 2, 3 ve 4. Sınıf)
Ders Kitabı

YAZARLAR

Prof. Dr. Emine Rya zmen
ğr. Gr. Dr. Arzu Doęanay Bilgi
Zehra Er
Arş. Gr. Gkhan Aıkgz



EDİTÖR

Prof. Dr. Emine Rya zmen

DİL UZMANI

Afife Nurten Aytac

GRSEL TASARIM VE RESİMLEME

Zuhal Harputođulları

Nazlı Elif Aktaş



İSTİKLÂL MARŞI

Korkma, sönmez bu şafaklarda yüzen al sancak;
Sönmeden yurdumun üstünde tüten en son ocak.
O benim milletimin yıldızıdır, parlayacak;
O benimdir, o benim milletimindir ancak.

Çatma, kurban olayım, çehreni ey nazlı hilâl!
Kahraman ırkıma bir gül! Ne bu şiddet, bu celâl?
Sana olmaz dökülen kanlarımız sonra helâl.
Hakkıdır Hakk'a tapan milletimin istiklâl.

Mehmet Âkif ERSOY

ANDIMIZ

Türküm, doğruyum, çalışkanım.

İlkem küçüklerimi korumak, büyüklerimi saymak; yurdumu, milletimi özümden çok sevmektir.

Ülküm yükselmek, ileri gitmektir.

Ey Büyük Atatürk!

Açtığın yolda, gösterdiğin hedefe durmadan yürüyeceğime ant içerim.





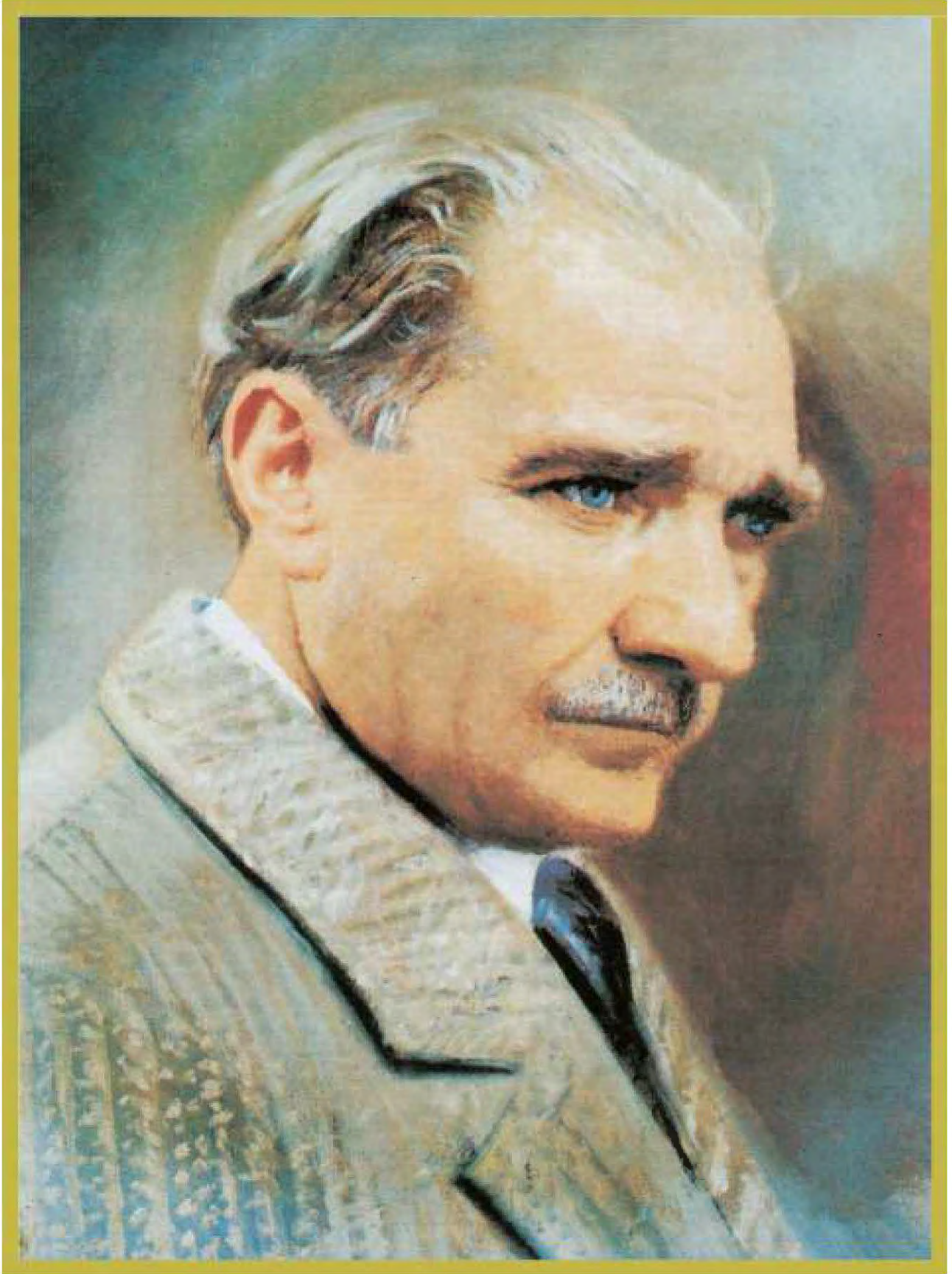

Varlığım Türk varlığına armağan olsun.

Ne mutlu Türküm diyene!



MUSTAFA KEMAL ATATÜRK

İçindekiler

Ee 	8
Ll 	20
Aa 	40
Kk 	68
İi 	94
Nn 	126
Kaynakça	156

İlk Okuma Yazma Seti Hakkında

Bu set harf gruplarına göre beş kitaptan oluşmaktadır. Kitaplarda ilk okuma yazma öğretim aşamaları benimsenmiştir. Etkinlikler önce hedef sesi ayırt etme, sesi okuma ve ilk temel harflerle yazma, sesi hece ve sözcük içinde okuma ve yazma, sesi cümle ve metin içinde okuma ve yazma ve son olarak sözcükleri, cümleleri anlama şeklindedir. Bu sırada hedeflerin gerçekleşmesi amacıyla etkinlikler çeşitlendirilmiştir. Etkinlikler arasında oyunlar (çark oyunları, resimli kart oyunları, dominolar), boyama, çizme, eşleme, yazma ve işaretleme etkinlikleri yer almaktadır.

Kitapta önce her bir ses için tanıtılan sesle başlayan sözcükleri ayırt etme ve söyleme, tanıtılan sesle biten sözcükleri ayırt etme ve söyleme etkinlikleri bulunmaktadır. Ardından tanıtılan sesi neyin çıkardığına ait bir görselle sesin küçük ve büyük harfi tanıtılmakta, çeşitli etkinliklerle sesi okuma, diğer sesler arasından gösterme, sözcükler içinde gösterme etkinlikleri yer almaktadır. Daha sonra kolaydan zora aşamalandırılmış şekilde tanıtılan sesin büyük ve küçük harfini yazma çalışmaları bulunmaktadır. Ayrıca "söylenildiğinde yazma" çalışmaları için de kitapta boş satır ayrılmıştır.

Hece aşamasında öğrenciye önce ünlü ile başlayan heceler tanıtılmaktadır. Bu aşamada öğrenciye her bir sesin farklı renk kutucukta yer aldığı örnek verilmekte, ayrıca yanında seslerin birleştirilmiş şekli yer almaktadır. Öğrenci önce hecelerin seslere ayrılmış hâlini görmekte sonra ise öğrenciden seslerin birleşmiş hâlini okuması istenmektedir. Bu aşamada her sesin altında noktalar bulunmaktadır. Böylece öğrenciye her sesi okuması için ipucu verilmiştir. Ayrıca bu noktaların altında hecelerin okunuş yönünü gösteren ok bulunmaktadır. Ünlü ile başlayan heceler okunduktan sonra bu hecelere ilgili etkinliklere yer verilmiştir. Öğrenci ünlü ile başlayan heceleri okumayı öğrendikten sonra öğrenciye ünsüz ile başlayan heceler verilmiştir. Bu heceler yine önce seslere ayrıştırılmış daha sonra bütün hâlinde verilmiştir. Üç sesli hecelerden mümkün olduğunca anlamlı sözcükler oluşturularak öğrencilerin bu hecelerin seslerinin nasıl birleştiğini görmelerine yönelik şemalarla bu heceler tanıtılmış ve hecelerin yazılması için satır ayrılmıştır.

Sözcük kısmında ise yine önce sözcüklerin hecelere bölünmüş hâlini öğrenciden okuması istenmiş, daha sonra hecede olduğu gibi renkli hecelere yazılmış her bir hecede bir nokta olan ve okunuş yönü okla gösterilen sözcükleri okuması istenmiştir. Aştirmaların zengin olduğu bu sette, ayrıca sözcük okuma yazma çalışmaları bazı etkili stratejilerden yola çıkılarak oluşturulmuş "Bak ve Yaz!" "Kapat ve Yaz!" "Aç, Karşılaştır, Yanlışsa Düzelt ve Yaz!" şeklinde tekniklere yer verilmiştir. Sözcük kısmında sadece okuma ve yazma değil aynı zamanda sözcük anlama bölümü de yer almaktadır. Bu bölümde sözcüğü resimle eşleme, sözcüğü belirten resmi seçme gibi bölümler bulunmaktadır. Kitaplarda görsel algıyı güçlendirmesi ve okuma hızına faydalı olması için "Sıra ile oku!" bölümleri bulunmaktadır. Bu bölümlerde öğrenciden, bir sözcüğün sonuna ekler getirerek yeni sözcükler türetmesi ya da sözcüklere yeni sözcükler eklenerek oluşturulacak cümleleri okuması istenmektedir. Yine bu bölümde sözcük yazma için sözcük tamamlama ve bakarak yazma etkinlikleri bulunmaktadır. Ayrıca kitapta, "söylenildiğinde yazma" çalışmaları için boş bir satır ayrılmıştır.

Son olarak cümle ve metin aşamasında öğrencilere seslerden oluşan cümlelerin okutularak yazdırılması hedeflenmiştir. Aynı zamanda cümle anlama etkinliklerine, cümleyi resimle eşleme ya da cümleyle ilgili sorulara uygun cevabı bulma etkinliklerine yer verilmiştir. Metinler ise öğrencilerin anlamasına hizmet etmek için resimlenmiş, mümkün olduğunca anlamlı metinler oluşturulmuştur. Öğrencilerin okumaya karşı olumlu tutum geliştirmeleri için heceleri, sözcükleri, cümleleri ve metinleri doğru okuduktan sonra yapılacak yıldız boyama, gülen yüz boyama, kutucuğa işaret koyma gibi etkinlikler yer almaktadır. Böylece öğrencinin okuma ve yazmayı pekiştirmesi sağlanmaktadır.

E e





Resimlere bak, "e" sesi ile başlıyorsa gülen yüzü, "e" sesi ile başlamıyorsa ağlayan yüzü boya.

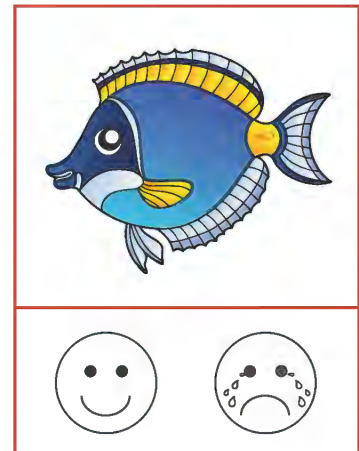
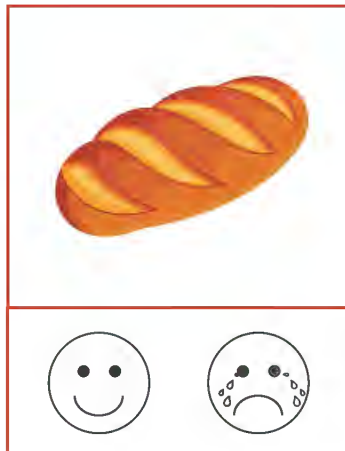
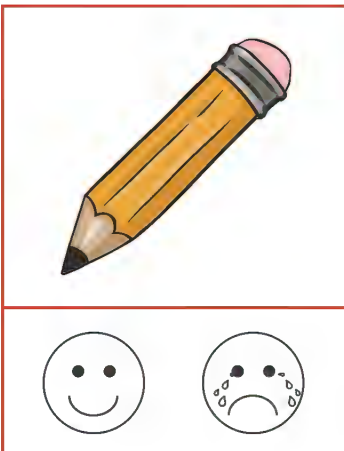
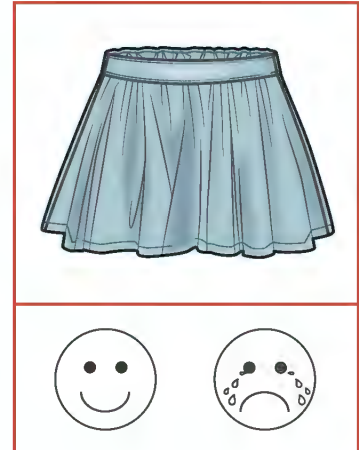
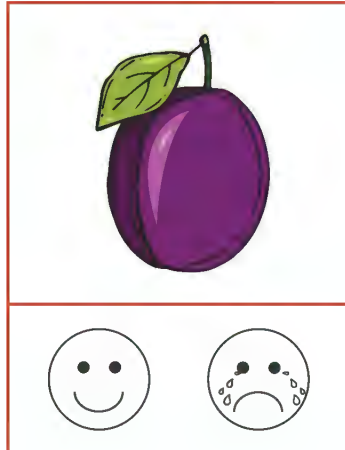
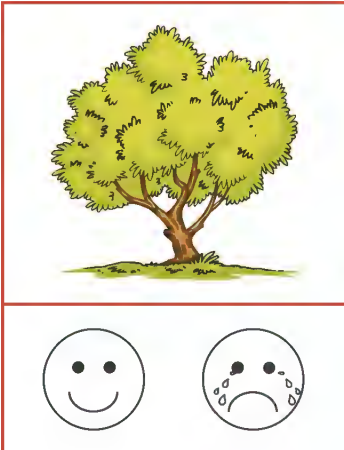
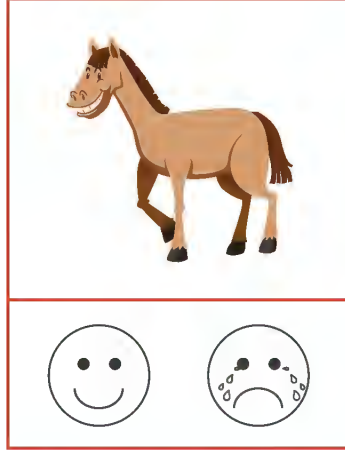
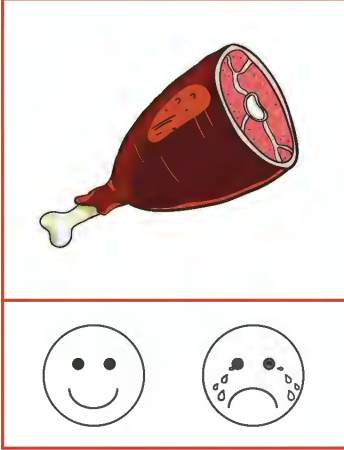



E sesini öğreniyorum.

Resimlere bak, "e" sesi ile bitiyorsa gülen yüzü, "e" sesi ile bitmiyorsa ağlayan yüzü boya.

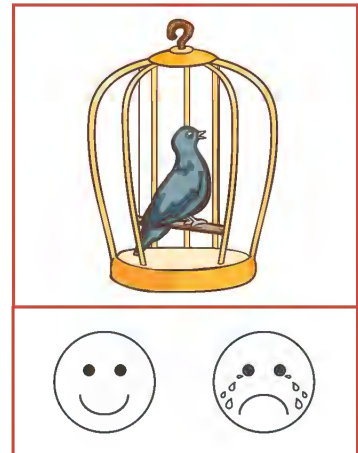
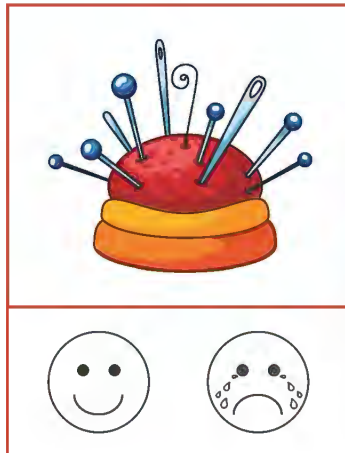
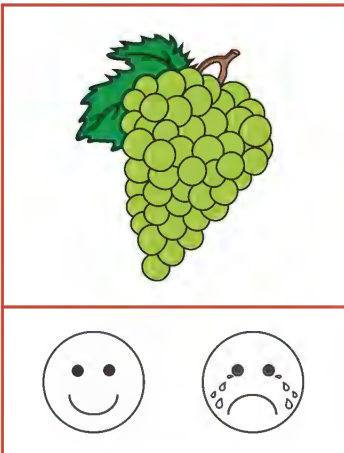
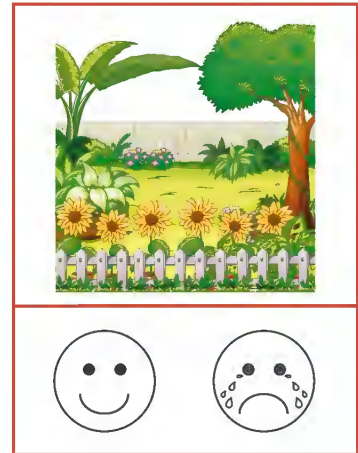
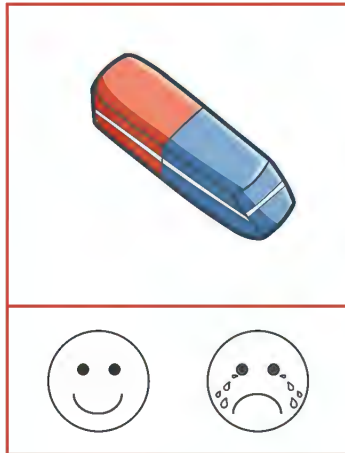



Aşağıdaki resimlerde yer alan varlıkların isimlerini söyle. Bu isimlerin hangi sesle başladığını söyle.



Aşağıdaki resimlerde yer alan varlıkların isimlerini söyle. Bu isimlerin hangi sesle bittiğini söyle.





E sesini öğreniyorum.

Sesi oku.



Resimlere bak, "e" harflerini "e" harfi ile başlayan resimlerle eşle.

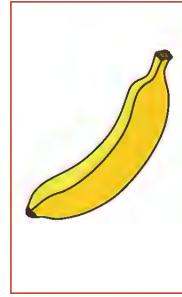

"e" harflerini bularak boya.

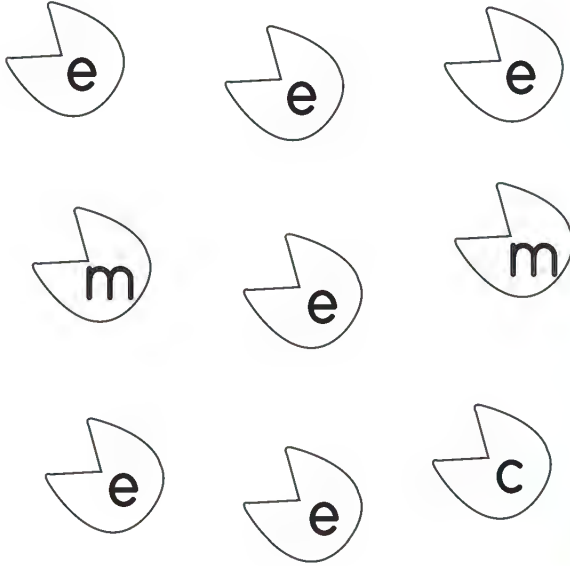

Tavşanın havuca ulaşması için "E" harflerini takip etmesi gerekiyor. "E" harflerini bularak tavşanı havuca götür.

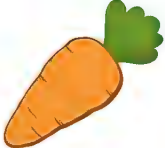
	E	C	E	E	E
A	E	E	E	M	E
D	A	N	F	D	



E sesini öğreniyorum.

Sözcüklerde yer alan "e" harflerini bulup işaretle.

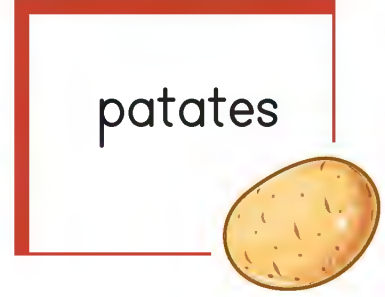

Sözcüklerde yer alan "E" harflerini bulup işaretle.

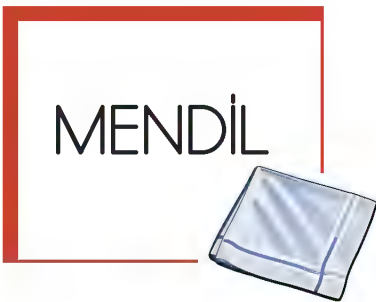



Oku çevir, "e" ile başlayan bir resim gelirse piyonunu bir kare ilerlet. "E" sesi ile başlayan bir resim gelmezse piyonunu bir kare geri çek. Yolun sonuna ilk gelen kazanır. Bu oyun iki kişi ile oynanır.



Birinci Oyuncu İkinci Oyuncu

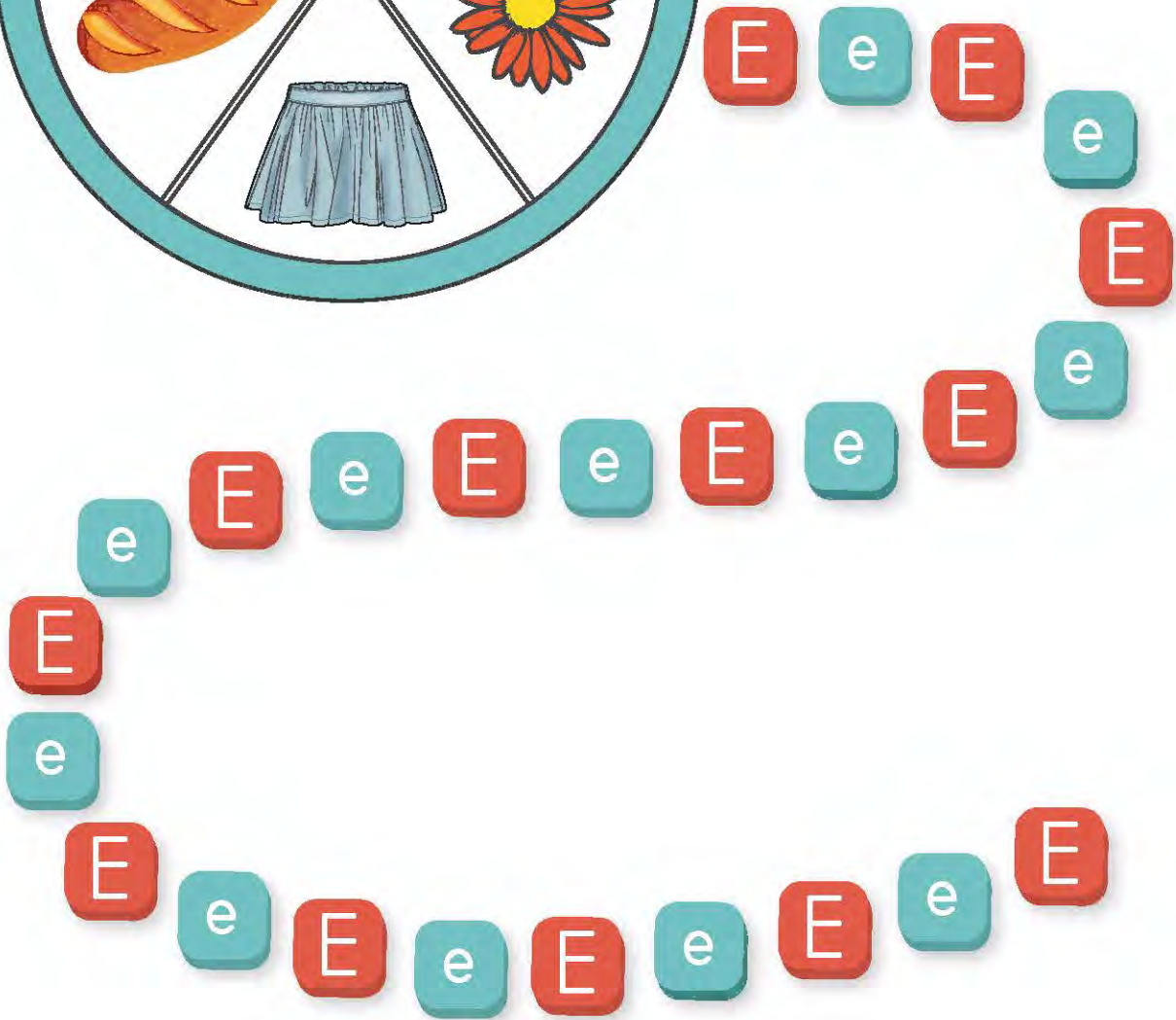



E sesini öğreniyorum.

Sesi oku.



Yaz.

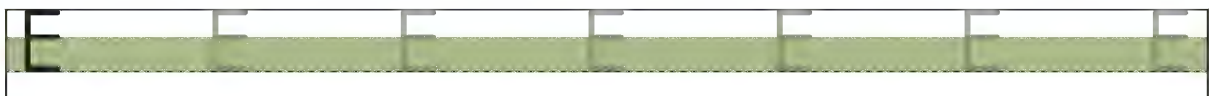
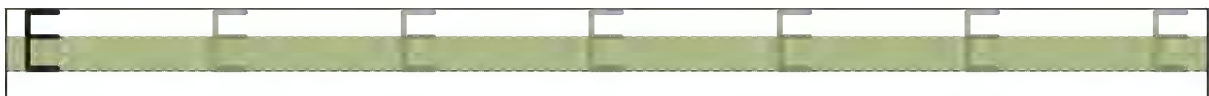



Yaz.

E

e

E

e



Söylediğim sesi yaz.

Blank handwriting practice line with a dashed midline and a green shaded bottom section.

Blank handwriting practice line with a dashed midline and a green shaded bottom section.

Blank handwriting practice line with a dashed midline and a green shaded bottom section.

Blank handwriting practice line with a dashed midline and a green shaded bottom section.



Metni 3 kez oku. Her okuduğunda bir gülen yüz boya.

EEEEEE

Eeeee  eeeee.

E e e e

Eeeee  eeeee.

E e e e e e





L l



Resimlere bak, "l" sesi ile başlıyorsa gülen yüzü, "l" sesi ile başlamıyorsa ağlayan yüzü boya.

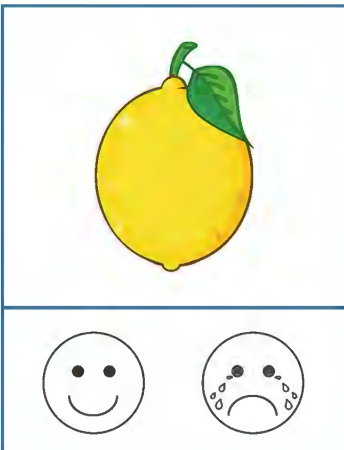
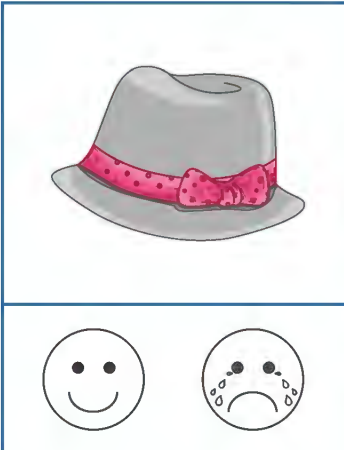
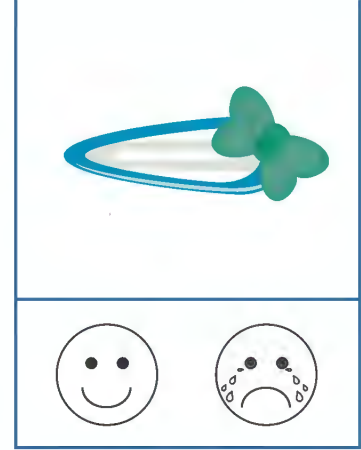
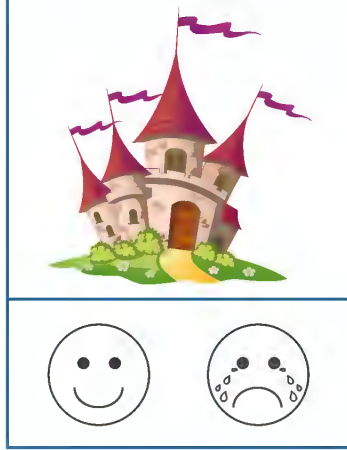
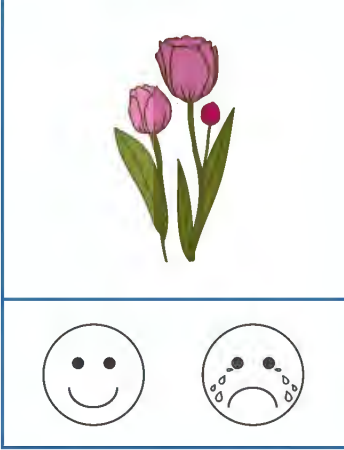

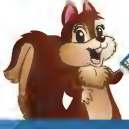

“l” sesini öğreniyorum.

Aşağıdaki her satırda “l” sesi ile başlayan bir resim vardır. Bu resmi bul ve söyle.

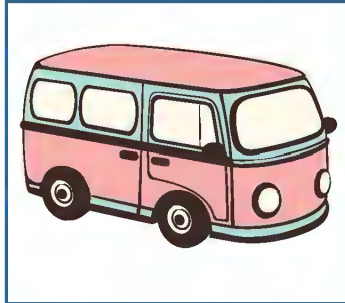
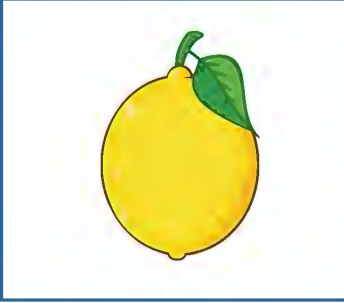

Resimlere bak, "l" sesi ile bitiyorsa gülen yüzü, "l" sesi ile bitmiyorsa ağlayan yüzü boya.

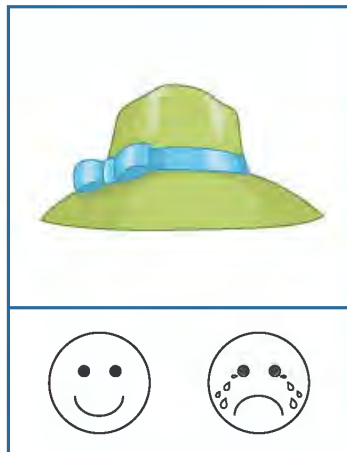
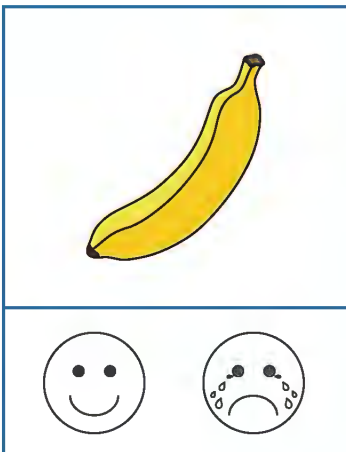
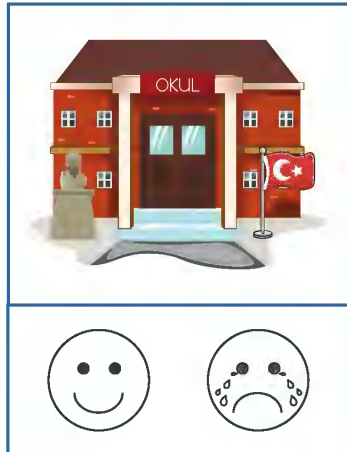
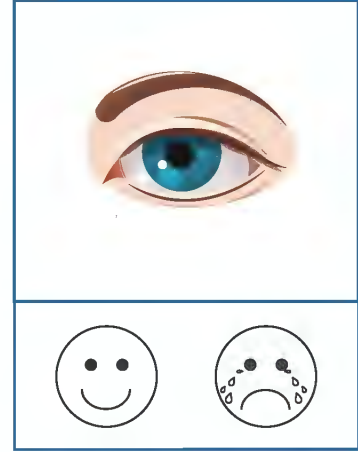
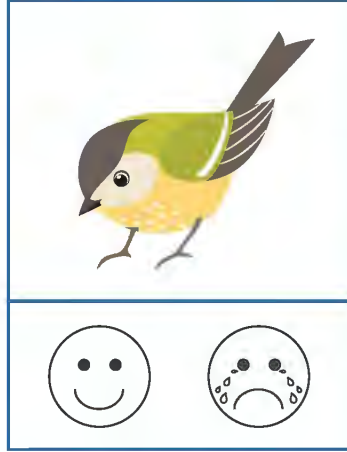
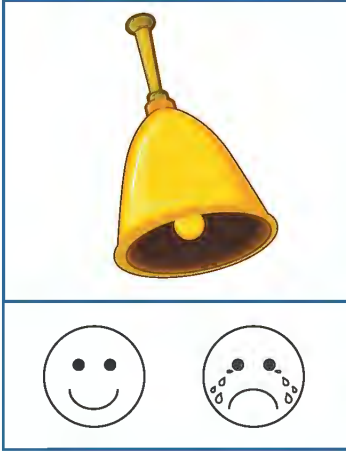



sesini öğreniyorun.

Aşağıdaki her satırda "l" sesi ile biten bir resim vardır. Bu resmi bul ve söyle.

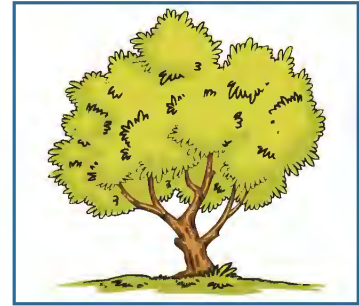
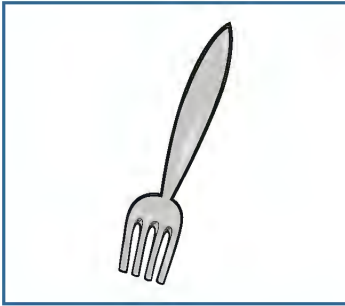
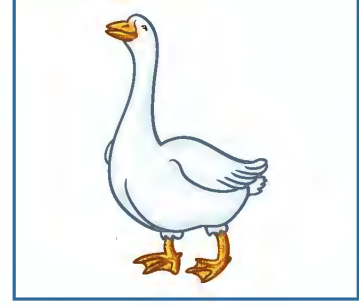
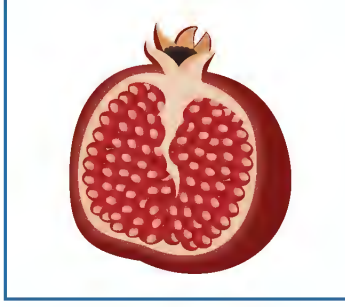



Sesi oku.



Resimlere bak, "l" harflerini "l" harfi ile başlayan resimlerle eşle.

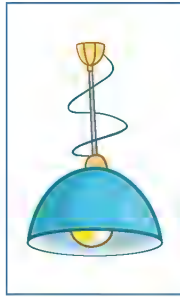
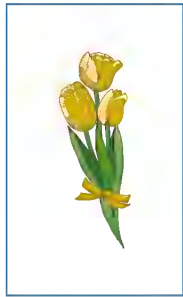



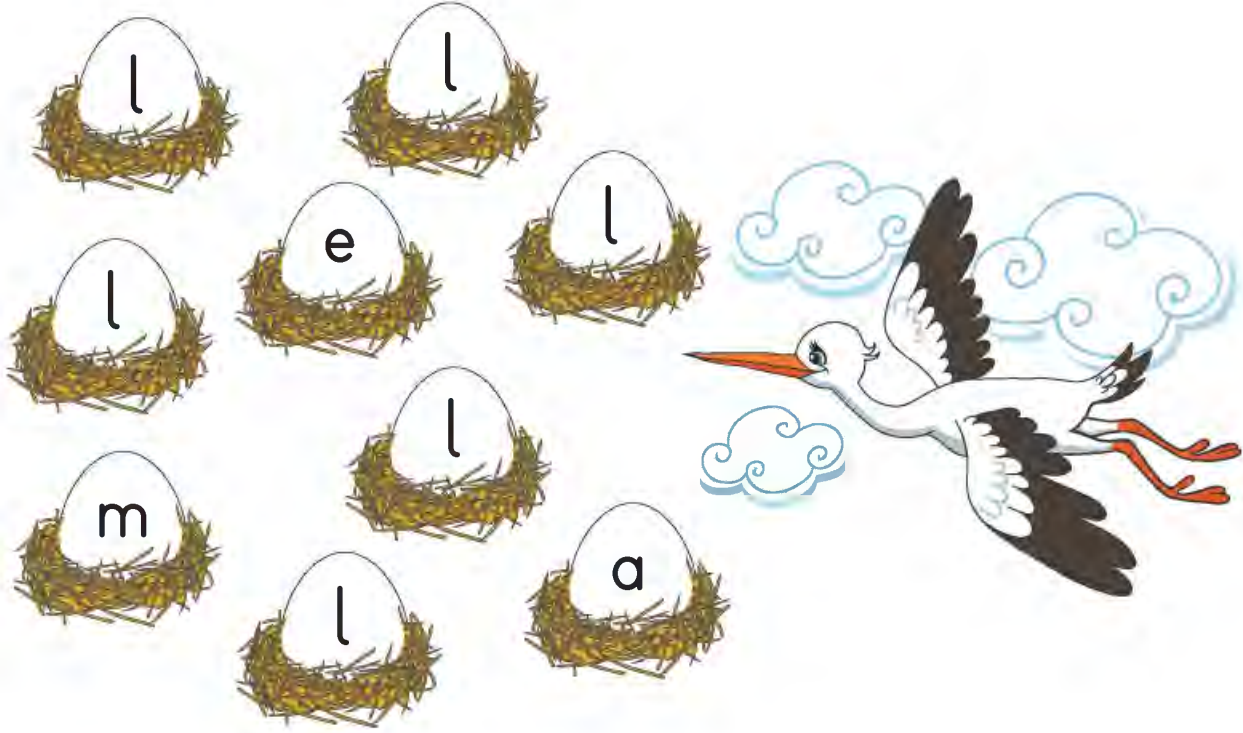

sesini öğreniyorum

"l" harflerini bularak boya.



Bebeğin ayısına ulaşması için "L" harflerini takip etmesi gerekiyor.
"L" harflerini bularak bebeği ayısına götür.



	E	L	L	L	E
L	K	L	N	L	N
L	L	L	K	L	

Sözcüklerde yer alan "l" harflerini bulup işaretle.

kelebek



elma



kol



lale



kalem



kalemlik



Sözcüklerde yer alan "L" harflerini bulup işaretle.

FANİLA



DOLAP



HALI

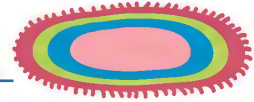

MENDİL

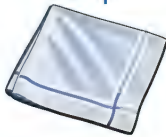

KALE



ÇATAL





sesini öğreniyorum

Sesi oku.



Yaz.

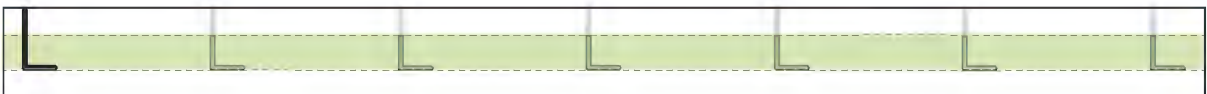
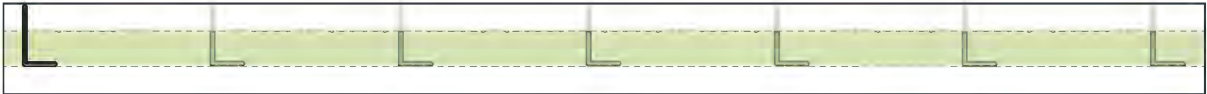
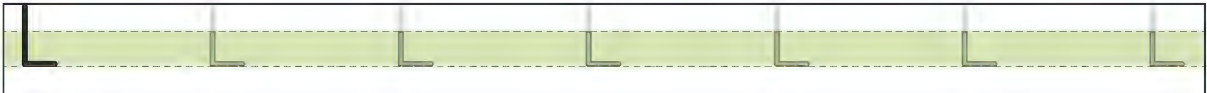



Yaz.

Handwriting practice line with a green dashed line and a solid green line. A small 'L' is written at the beginning.

Handwriting practice line with a green dashed line and a solid green line. A small 'L' is written at the beginning.

Handwriting practice line with a green dashed line and a solid green line. A small 'L' is written at the beginning.

Handwriting practice line with a green dashed line and a solid green line. A small 'L' is written at the beginning.



Söylediğim sesi yaz.

Handwriting practice line with a green dashed line and a solid green line.

Handwriting practice line with a green dashed line and a solid green line.

Handwriting practice line with a green dashed line and a solid green line.

Handwriting practice line with a green dashed line and a solid green line.



sesini öğreniyordun

Sözcüğü oku ve yaz.



e l el



e l el



e l el



Sözcükleri oku. Okuduğun sözcüğün yanındaki yıldızı boya.

<p>e l</p> <p>→</p>	<p>☆</p>	<p>e l</p> <p>→</p>	<p>☆</p>
<p>e l</p> <p>→</p>	<p>☆</p>	<p>e l</p> <p>→</p>	<p>☆</p>

Yaz.

el

el

el

el

Söylediğim sözcüğü yaz.









sesini öğreniyorduk

Heceyi oku ve yaz.

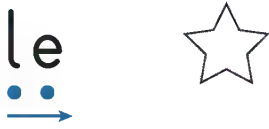

Heceleri oku. Okuduğun hecenin yanındaki yıldızı boya.

Yaz.

le

le

le

le



Söylediğim heceyi yaz.



sesini öğreniyordun

Sözcükleri oku ve yaz.

el

el



e le

ele



el le

elle



Sözcükleri oku. Okuduğun sözcüğün yanındaki yıldızı boya.

<p>el</p> <p>•</p> <p>→</p>	<p>☆</p>	<p>elle</p> <p>• •</p> <p>→</p>	<p>☆</p>
<p>e le</p> <p>• •</p> <p>→</p>	<p>☆</p>		



Yaz.

el

ele

elle

el



Söylediğim sözcükleri yaz.



L sesini öğreniyorum.

Cümleleri oku. Okuduğun cümlenin yanındaki yıldızı boya.

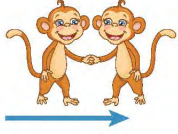

el ele.



El ele.



el ele.





Cümleri yaz. Cümleri yazdıktan sonra kutucuğu işaretle.

 el ele.





El ele. 

 el ele.







Metinleri 3 kez oku. Her okuduğunda bir gülen yüz boya.

ELE

 ele.
Ele ele  ele.
Ele   ele.



EL ELE

 el ele.
 el ele.
 el ele.





A

a



Aşağıdaki resimlerde yer alan varlıkların isimlerini söyle. Bu isimlerin hangi sesle başladığını söyle.

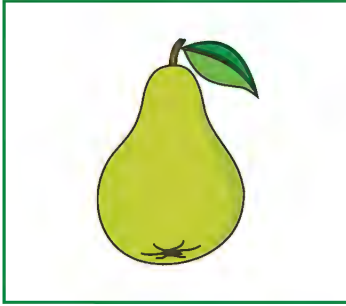
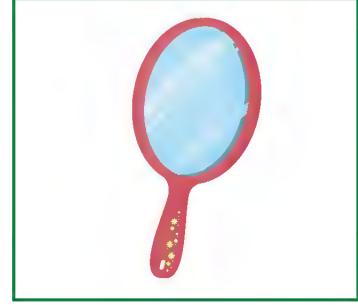

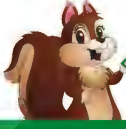

A sesini öğreniyorum.

Oku çevir, "a" sesi ile başlayan bir resim gelirse iki kare ilerlet.
"A" sesi ile başlayan bir resim gelmezse piyonunu iki kare geri çek.
Yolun sonuna ilk gelen oyunu kazanır. Bu oyun iki kişi ile oynanır.

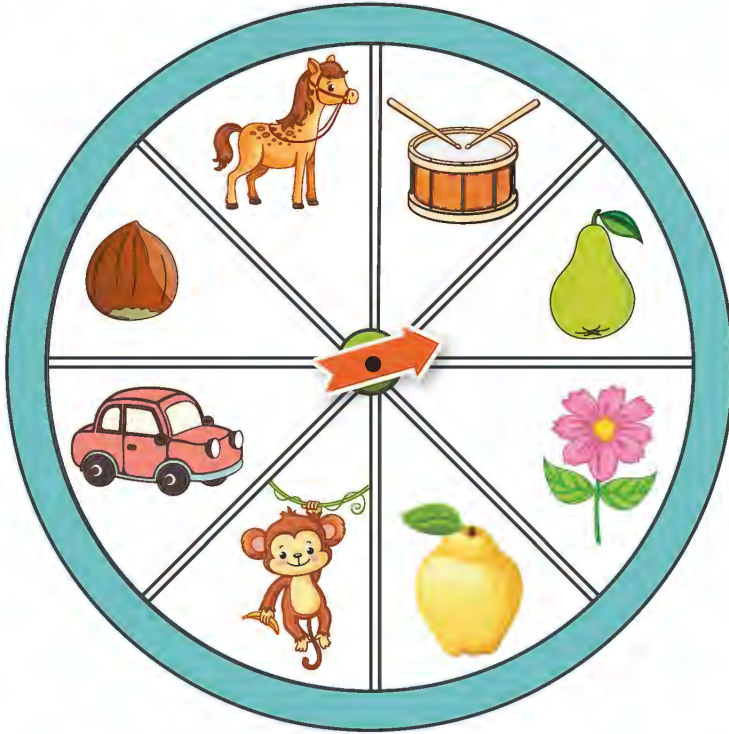

Birinci Oyuncu İkinci Oyuncu

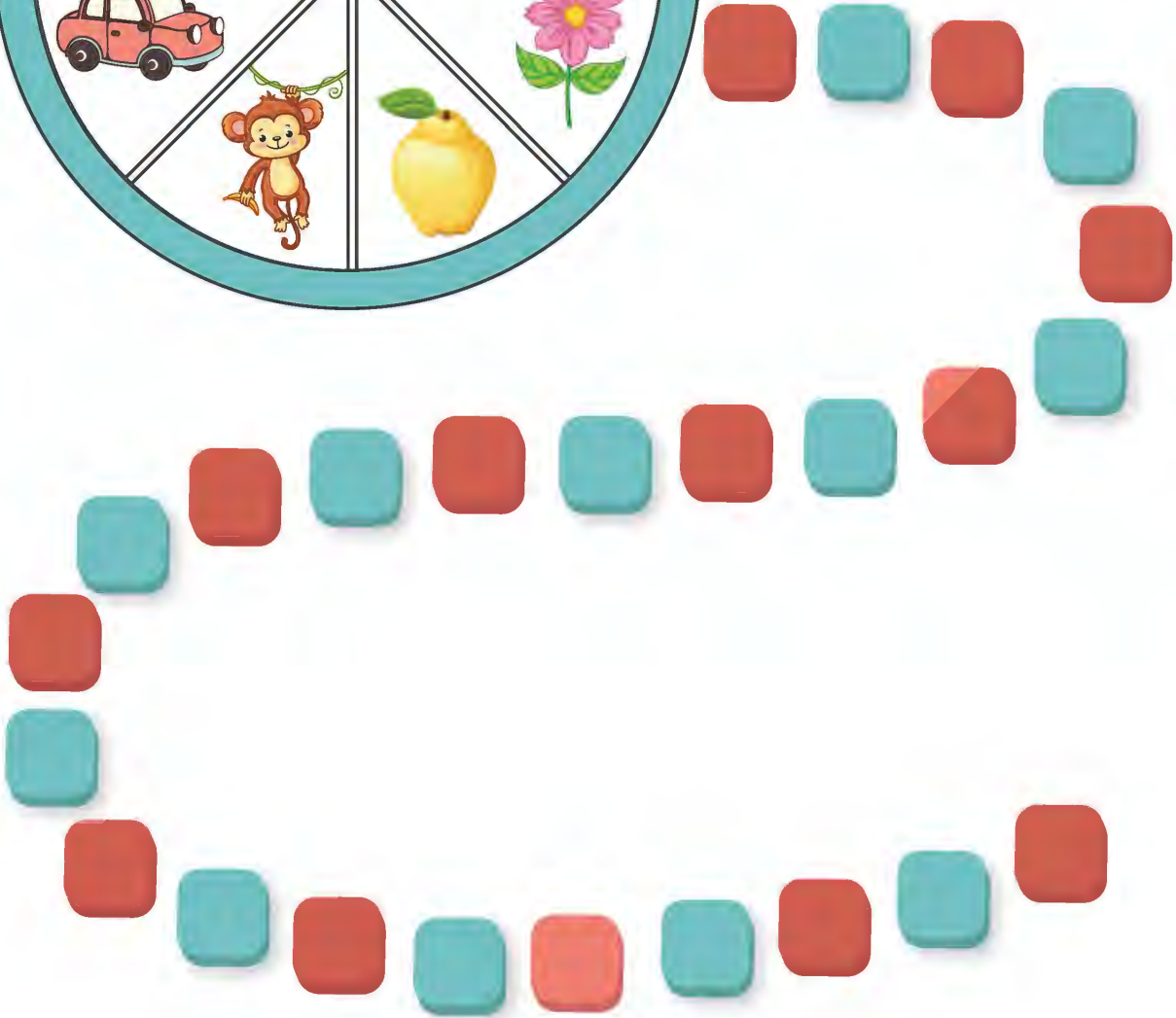

Resimlere bak, "a" sesi ile bitiyorsa gülen yüzü, "a" sesi ile bitmiyorsa ağlayan yüzü boya.

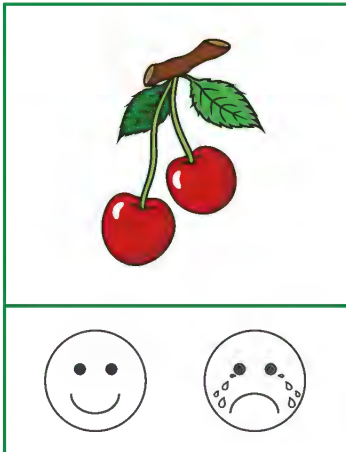
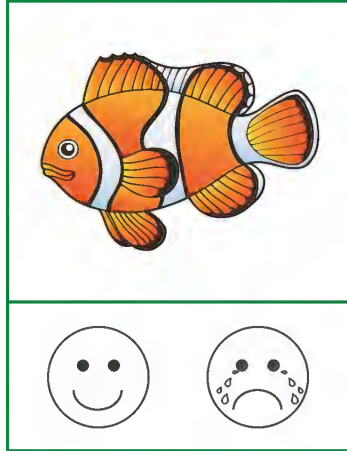
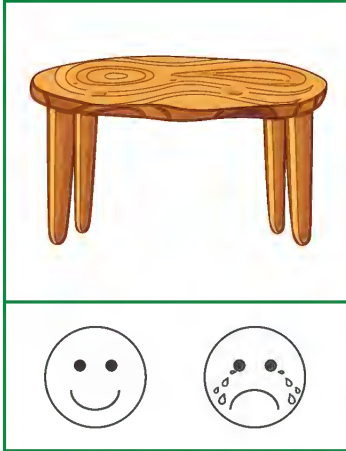
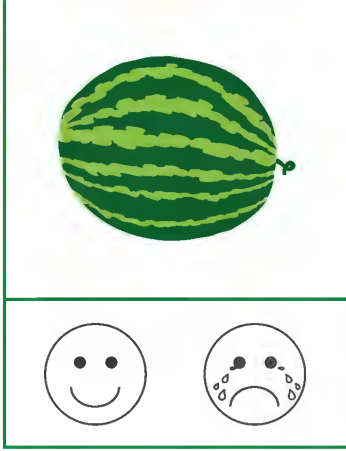



“a” sesini öğreniyorum.

Aşağıdaki her satırda “a” sesi ile biten bir resim vardır. Bu resmi bul ve söyle.

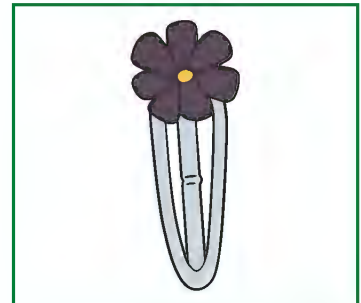

Sesi oku.



Resimlere bak, "a" harflerini "a" harfi ile başlayan resimlerle eşle.



a

a

a

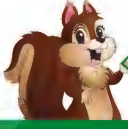

A sesini öğreniyorum.

Resimlere bak, "A" harflerini "A" harfi ile başlayan resimlerle eşle.



A



Resimlerin hangi sesle başladığını bulup bulduğun sesi daire içine al.

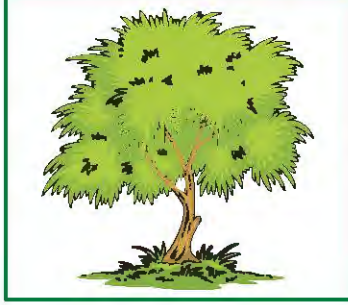

a l

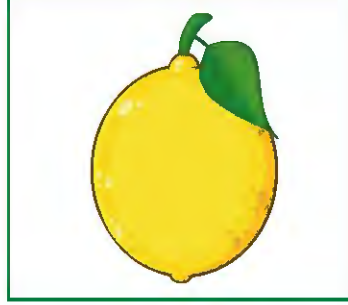

e l



a e



e l



a l

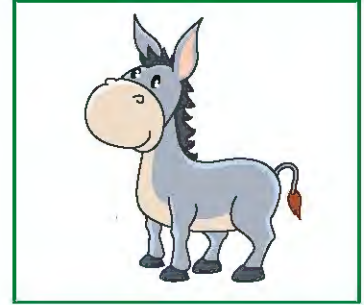

e a



a e



e a

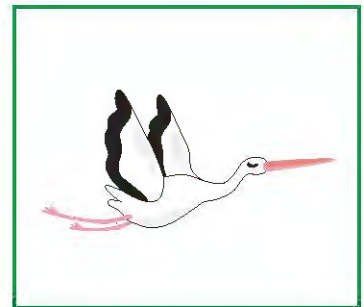

l a



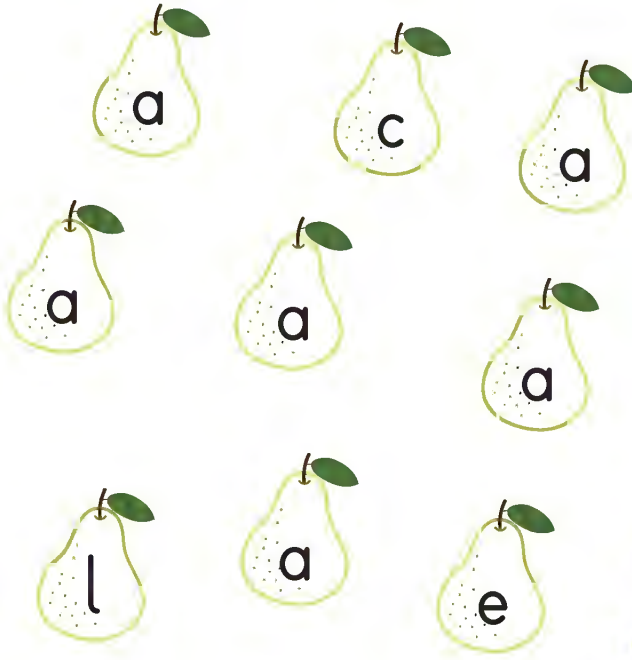

Harflerini öğreniyorum.

"a" harflerini bularak boya.



Robotun Aliye gitmesi için "A" harflerini takip etmesi gerekiyor.
"A" harflerini bularak robotu Aliye götür.

	A	A	A	A	E
L	K	L	E	A	K
K	L	E	K	A	

Sözcüklerde yer alan "a" harflerini bulup işaretle.

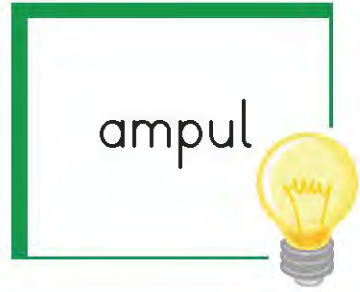
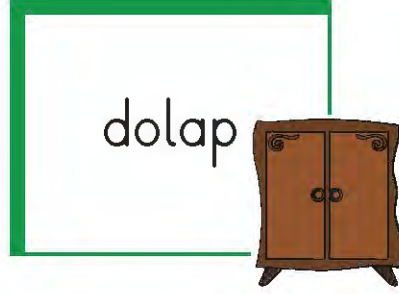

Sözcüklerde yer alan "A" harflerini bulup işaretle.

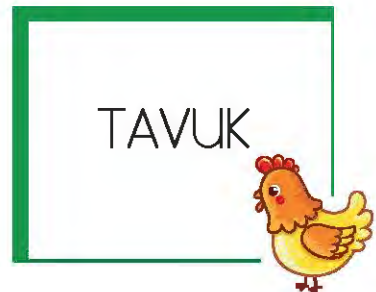
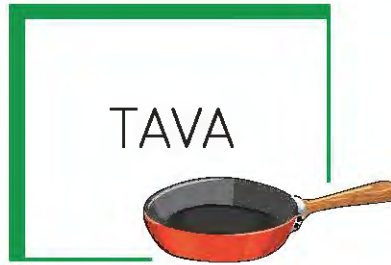



İlim öğreniyorum.

Sesi oku.

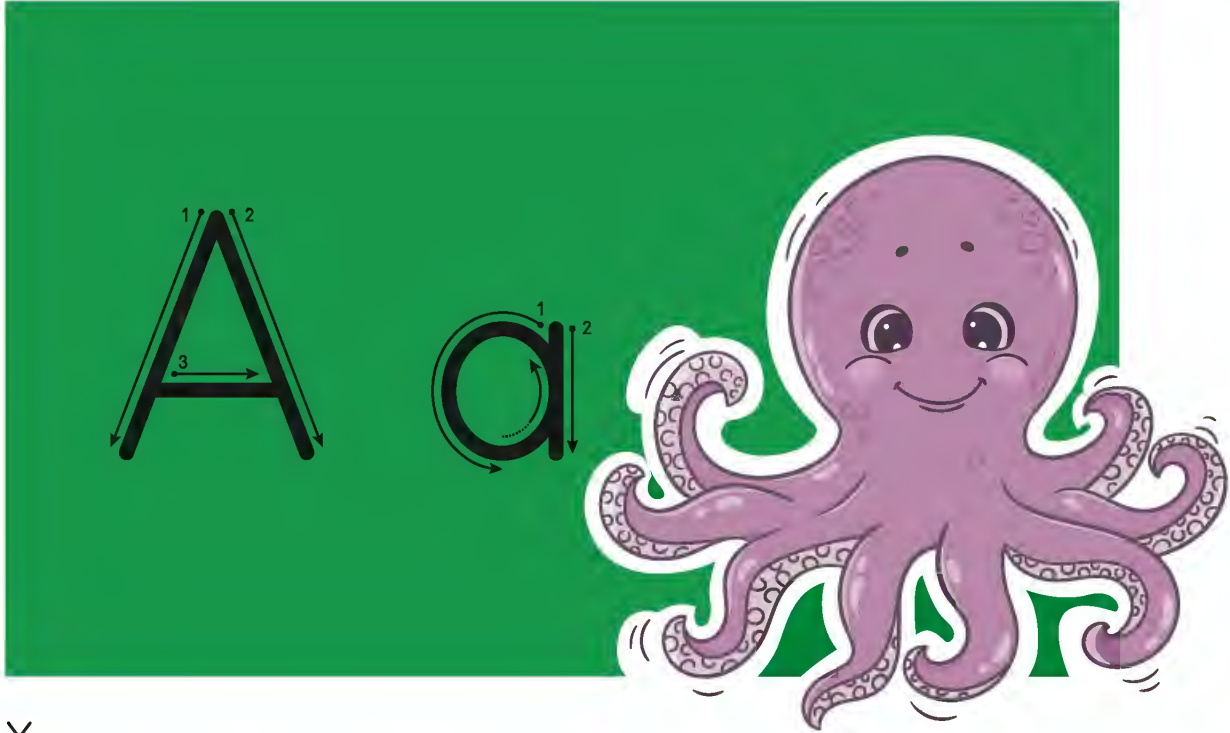

Yaz.

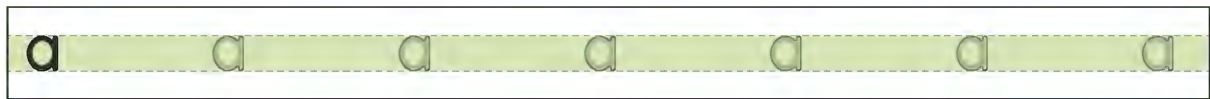

Yaz.

A

a

A

a



Söylediğim sesi yaz.

Blank handwriting line for writing the sound of the letter 'A'.

Blank handwriting line for writing the sound of the letter 'A'.

Blank handwriting line for writing the sound of the letter 'A'.

Blank handwriting line for writing the sound of the letter 'A'.



Okumam öğreniyordum.

Sözcüğü oku ve yaz.



Sözcükleri oku. Okuduğun sözcüğün yanındaki yıldızı boya.

Baştaki ses ve sözcükleri oku. Her satırda farklı olan ses ve sözcükleri bul.

a	a	a	a	e	a	a	e	a
al	al	al	al	el	al	al	al	el
e	e	e	e	a	e	e	a	e
el	el	el	al	al	el	el	al	el

Söylediğim sözcükleri yaz.



Okumak Zorunludur

Heceyi oku ve yaz.



Heceleri oku. Okuduğun hecenin yanındaki yıldızı boya.

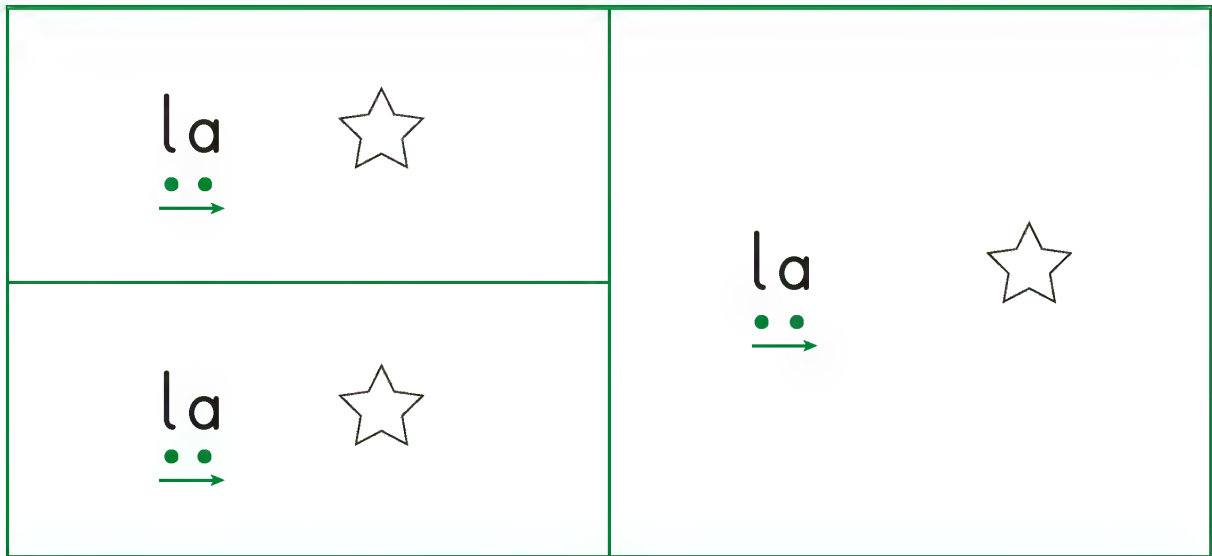

Baştaki hece ve sözcükleri oku. Her satırda farklı olan hece ve sözcükleri bul.

le	le	le	al	le	el	le	la	le
al	al	al	a	al	al	e	al	a
el	el	el	el	el	el	al	el	la
la	la	la	le	la	al	le	al	al

Söylediğim heceleri yaz.



Okumayı öğreniyorsanız

Sözcükleri oku ve yaz.

a l al →

a l al →

a l al →

E la Ela →

E la Ela →

E la Ela →

Sözcükleri oku ve yaz.

ala ala



ala ala



ala ala



lale lale



lale lale



lale lale





İncelemeye başlıyoruz

Sözcükleri oku ve yaz.

e le ele →

e le ele →

e le ele →

el le elle →

el le elle →

el le elle →

Sözcükleri oku ve yaz.

a

la

la

la

The diagram shows a blue rounded square containing the letter 'a'. Three arrows point from this 'a' to three yellow rounded squares, each containing the word 'la'. Each 'la' is connected by an arrow to a set of three horizontal writing lines (top, middle, bottom) with a light green background.

la

le

le

le

The diagram shows a blue rounded square containing the word 'la'. Three arrows point from this 'la' to three yellow rounded squares, each containing the word 'le'. Each 'le' is connected by an arrow to a set of three horizontal writing lines (top, middle, bottom) with a light green background.



Her kelimeyi öğreniyordum.

Sözcükleri oku ve yaz.

e

la

la

la

el

le

le

le



Sözcükleri oku. Okuduğın sözcüğün yanındaki yıldızı boya.

al • →	☆	lale • • →	☆
ela • • →	☆	ele • • →	☆
ala • • →	☆	elle • • →	☆





Bak ve yaz.	Kapat ve yaz.	Aç, karşılaştır yanlışsa düzelt ve yaz. Oku.
al _ _ _ _ _	_ _ _ _ _	_ _ _ _ _
ela _ _ _ _ _	_ _ _ _ _	_ _ _ _ _
ala _ _ _ _ _	_ _ _ _ _	_ _ _ _ _
lale _ _ _ _ _	_ _ _ _ _	_ _ _ _ _
ele _ _ _ _ _	_ _ _ _ _	_ _ _ _ _
elle _ _ _ _ _	_ _ _ _ _	_ _ _ _ _



Yaz.

al

ela

ala

lale

ele

elle



Söylediğim sözcükleri yaz.

Blank writing line for the first word.

Blank writing line for the second word.



A sesini öğreniyorum.

Cümleleri oku. Okuduğun cümlelerin yanındaki yıldızı boya.

Ela el ele.
→



Ela  al.
→



Ela lale al.
→



Ela  elle.
→



Sıra ile oku.

Ela

Ela lale

Ela lale al.





Cümleleri yaz. Cümleleri yazdıktan sonra kutucuğu işaretle.

Ela lale al.

Lale ala  al.

Söylediğim cümleleri yaz.

Metni 3 kez oku. Her okuduğunda bir gülen yüz boya.

LALE

Ela lale al.

Ela, Lale el ele.

Lale ~~lale~~ lale al.

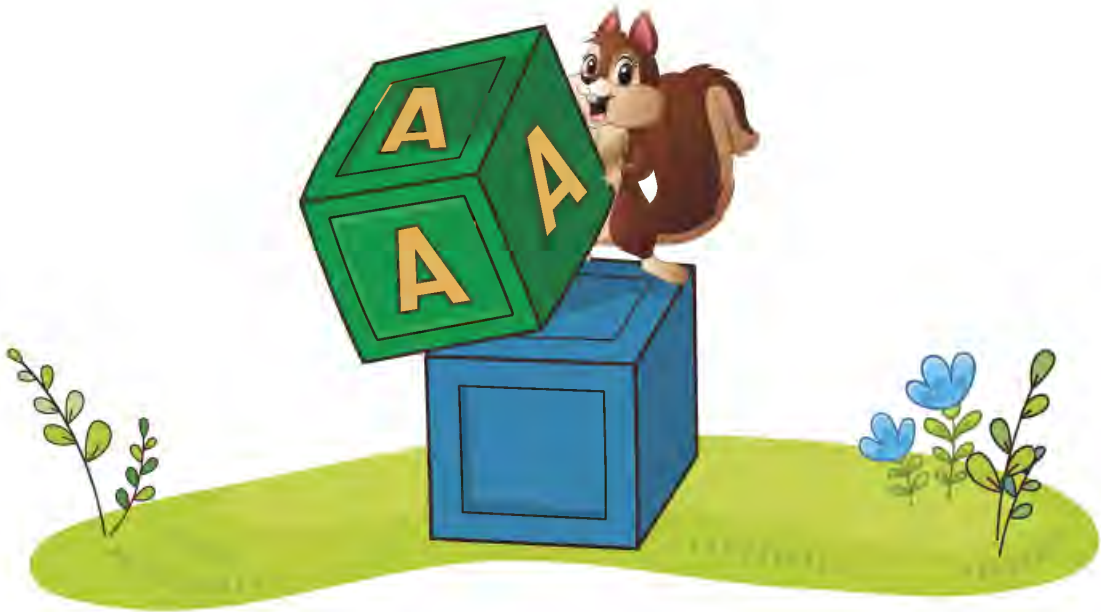

K k





Resimlere bak, "k" sesi ile başlayan hayvanları işaretle ve isimlerini söyle.





K sesini öğreniyorum.

“K” ile biten resimlerin bulunduğu kutuyu işaretle ve isimlerini söyle.

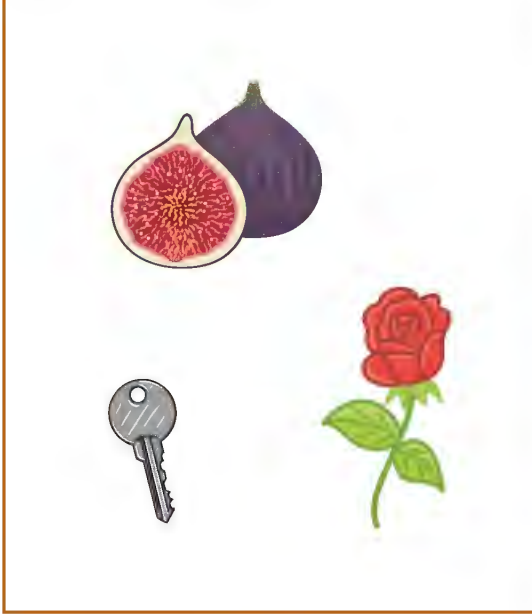



Sesi oku.



Resimlere bak, "k" harflerini "k" harfi ile başlayan resimlerle eşle.

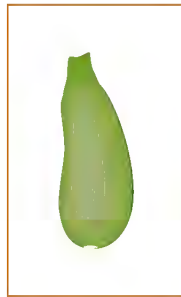
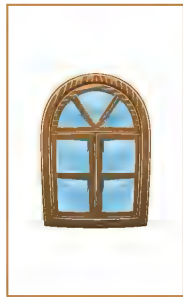

k

k

k



K sesini öğreniyorum.

Resimlerin hangi sesle başladığını bulup bulduğun sesi daire içine al.



k l

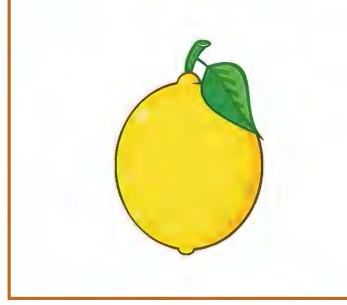

l a



a e



l k



a k



k a



a k

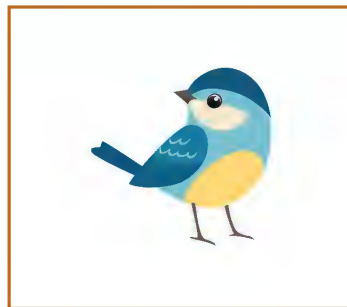

k e



l e

"k" harflerini bularak boya.

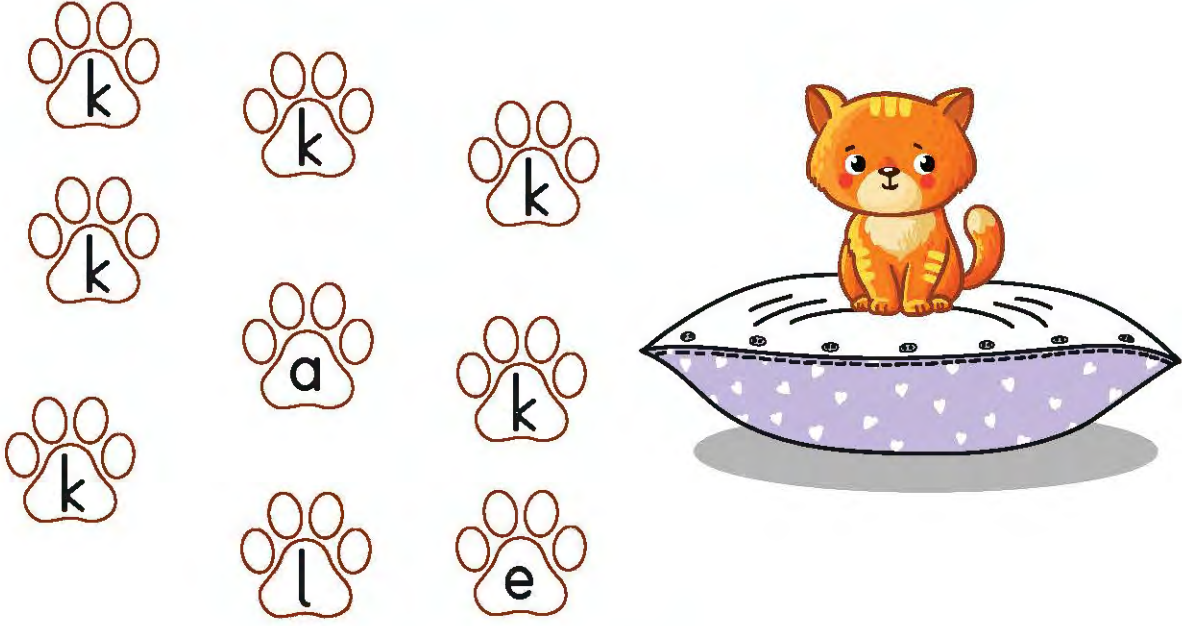

"K" harflerini bularak boya.

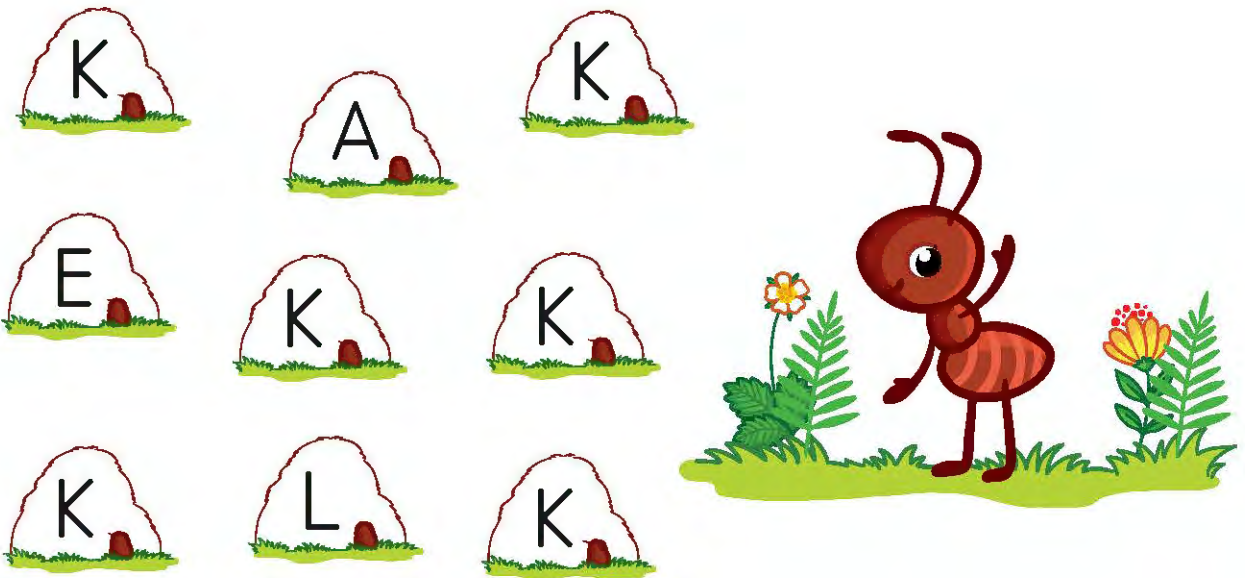



K sesini öğreniyorum.

Aynı harfleri eşleştir ve oku.

A

K

l

a

E

e

k

L



Sözcüklerde yer alan "k" harflerini bulup işaretle.

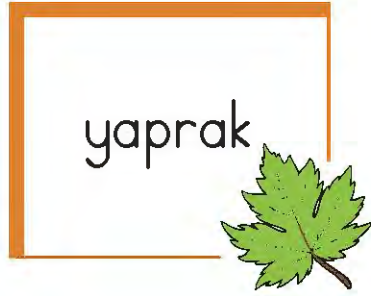

Sözcüklerde yer alan "K" harflerini bulup işaretle.





K sesini öğreniyorum.

Sesi oku.



Yaz.

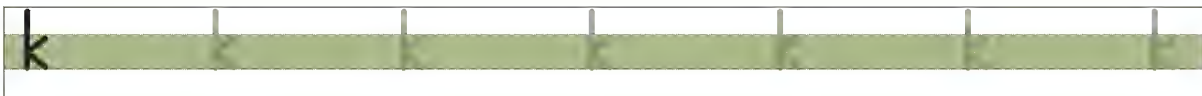
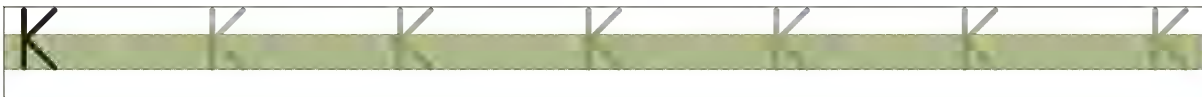
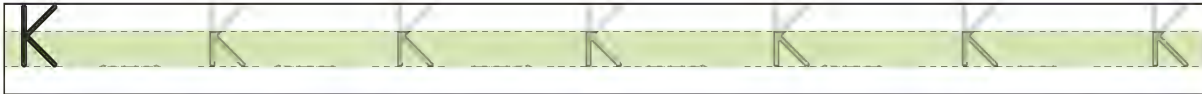



Yaz.



Söylediğim sesi yaz.





K sesini öğreniyorum.

Sözcükleri oku ve yaz.

a k ak →

e k ek →

Sözcükleri oku ve yaz.

la la la k →

Heceleri oku ve yaz.

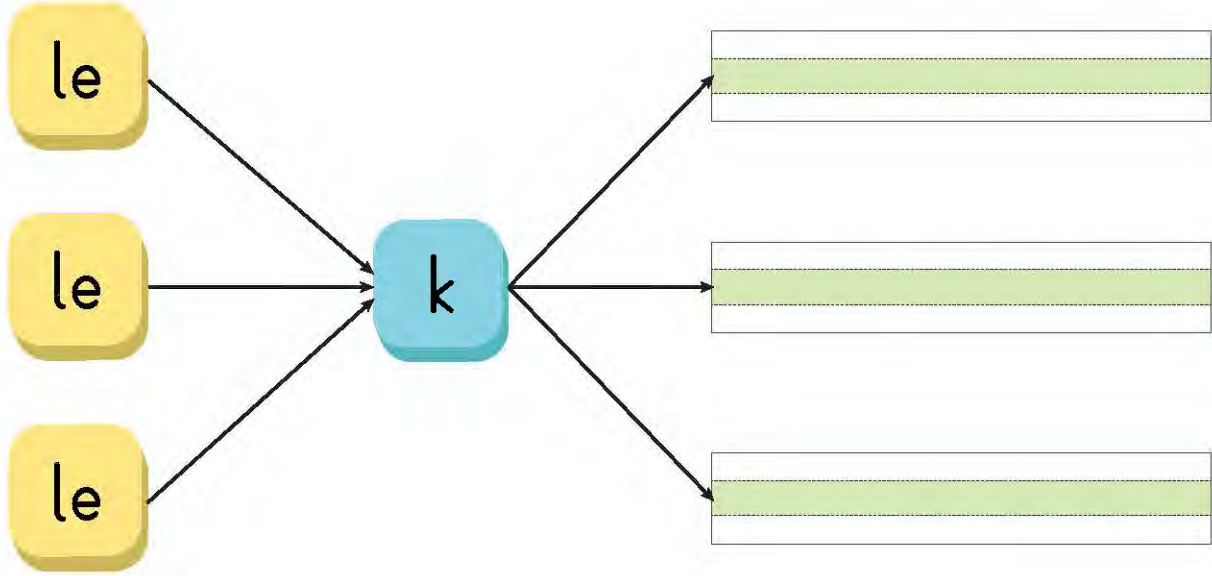

Hece ve sözcükleri oku. Okuduğun hece ve sözcüğün yanındaki yıldızı boya.



K sesini öğreniyorum.

Baştaki hece ve sözcükleri oku. Her satırda farklı olan hece ve sözcükleri bul.

ak	ak	ak	ek	ak	el	ak	ak	al
ek	ek	al	ek	a	ek	a	ek	ek
lak	lak	lak	lak	lek	ek	lak	lak	lak
lek	lek	lek	ek	lek	ak	lek	lek	ek

Söylediğim hece ve sözcükleri yaz.

Handwriting practice line with a dashed midline and a solid top and bottom line.

Handwriting practice line with a dashed midline and a solid top and bottom line.

Handwriting practice line with a dashed midline and a solid top and bottom line.

Handwriting practice line with a dashed midline and a solid top and bottom line.

Heceleri oku ve yaz.



Sözcükleri oku ve yaz.

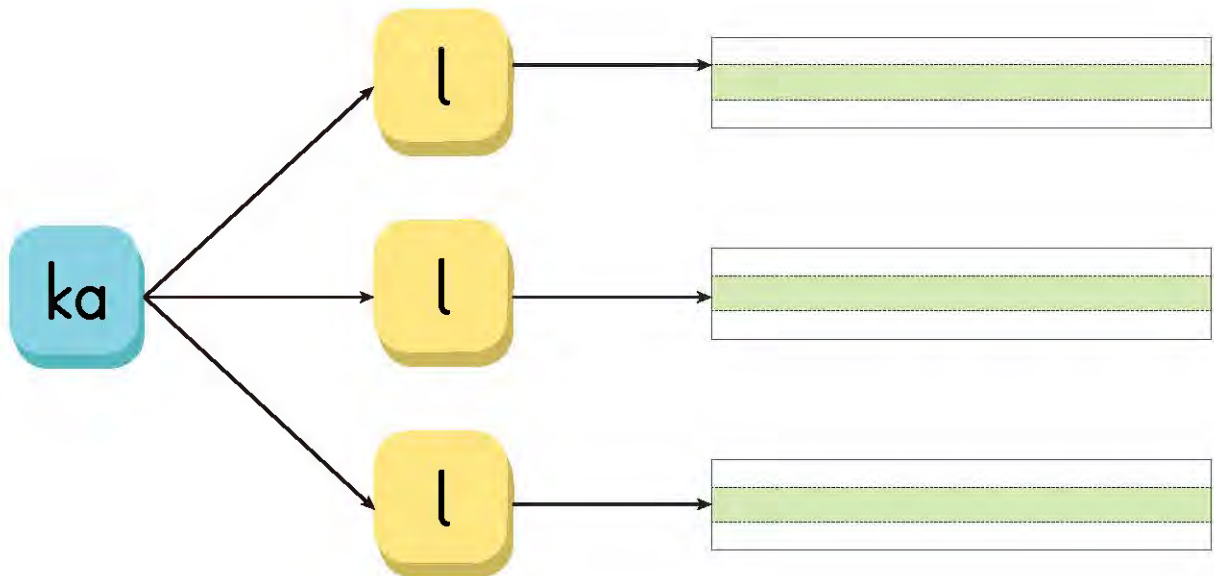



K sesini öğreniyorum.

Sözcükleri oku ve yaz.

ke

l

l

l

l

l

l

l

ke

k

k

k

k



k

k

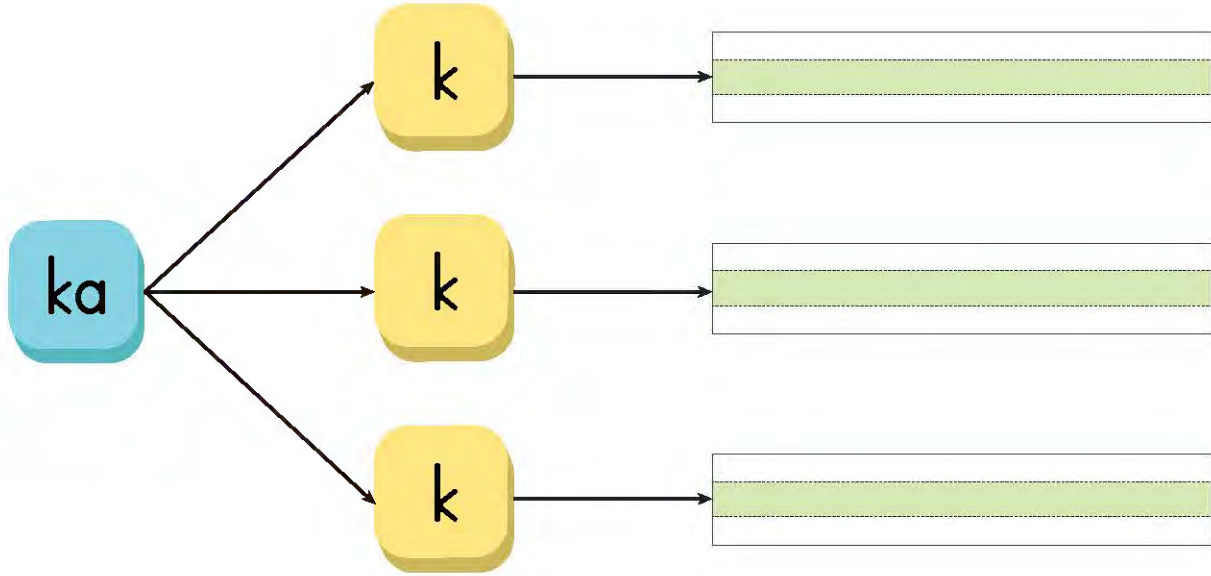
Heceleri oku ve yaz.



Hece ve sözcükleri oku. Okuduğun hece ve sözcüğün yanındaki yıldızı boya.

ke 		kel 	
ka 		kek 	
kal 		kak 	



K sesini öğreniyorum.

Tabloda yer alan hece ve sözcükleri soldan sağa, yukarıdan aşağıya doğru oku.

kal	kal	kal	kal
kel	kel	kel	kel
kek	kek	kek	kek
ke	ke	ke	ke
kak	kak	kak	kak

Söylediğim heceleri yaz.



Hecelerine ayrılmış sözcükleri oku ve yaz.

ek

le

Handwriting practice line with a green shaded area and a dashed midline.

kek

Handwriting practice line with a green shaded area and a dashed midline.

ak

la

Handwriting practice line with a green shaded area and a dashed midline.

e

lek

Handwriting practice line with a green shaded area and a dashed midline.

ka

le

Handwriting practice line with a green shaded area and a dashed midline.

e

lek

le

Handwriting practice line with a green shaded area and a dashed midline.

le

ke

Handwriting practice line with a green shaded area and a dashed midline.

kalk

Handwriting practice line with a green shaded area and a dashed midline.

ka

la

Handwriting practice line with a green shaded area and a dashed midline.

ke

ke

Handwriting practice line with a green shaded area and a dashed midline.



K sesini öğreniyorum.

Sözcükleri oku. Okuduğun sözcüğün yanındaki yıldızı boya.

ekle • • →	☆	kek • →	☆
akla • • →	☆	elek • • →	☆
kale • • →	☆	elekle • • • →	☆
leke • • →	☆	kalk • →	☆
kala • • →	☆	keke • • →	☆





Oku çevir ve gelen sözcüğü oku. Aşağıda verilen sözcük kartında, çarkta gelen aynı sözcüğü bul ve üstünü kapat. Tüm sözcüklerin üstünü kapattığında oyun biter.

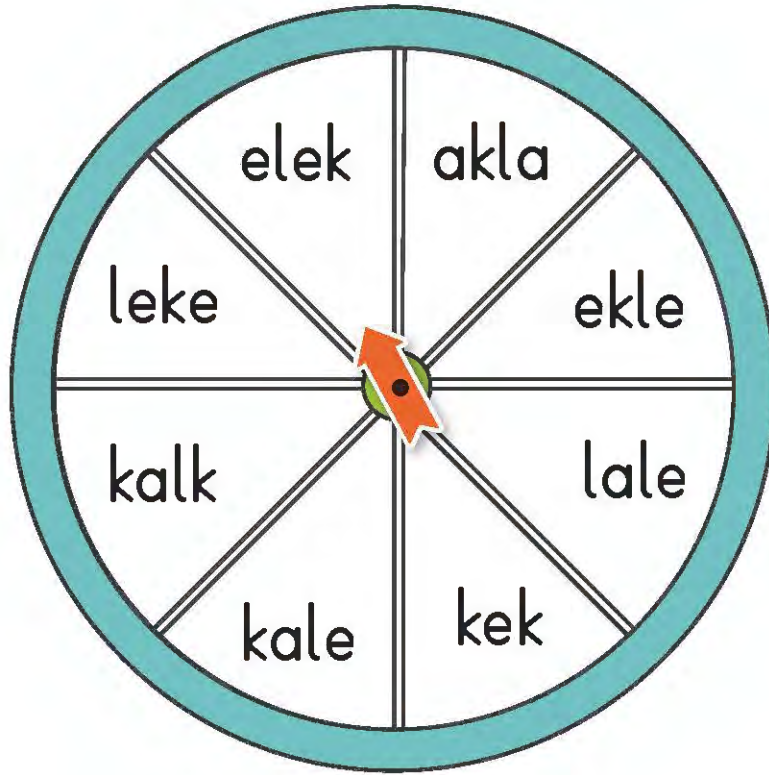

elek	akla	ekle	kek
lale	kale	kalk	leke



K sesini öğreniyorum.

Yaz.

elek

akla

ekle

kek

lale

kale

kalk

Söylediğim sözcükleri yaz.

Blank writing line for the first word.

Blank writing line for the second word.



Cümleleri oku. Okuduğun cümlenin yanındaki yıldızı boya.

Ela  ekle.
→



Ela elekle  ele.
→



Ela kek al.
→



Lale  leke.
→



Kalk Ela kalk.
→





K sesini öğreniyorum.

Cümleleri yaz. Cümleleri yazdıktan sonra kutucuğu işaretle.

Ela  ekle.

Ela elekle  ele.

Ela kek al.

Lale  leke.

Söylediğim cümleleri yaz.

Handwriting practice line with a solid green top bar, a dashed middle line, and a solid bottom bar.

Handwriting practice line with a solid green top bar, a dashed middle line, and a solid bottom bar.

Handwriting practice line with a solid green top bar, a dashed middle line, and a solid bottom bar.

Handwriting practice line with a solid green top bar, a dashed middle line, and a solid bottom bar.

Handwriting practice line with a solid green top bar, a dashed middle line, and a solid bottom bar.

Handwriting practice line with a solid green top bar, a dashed middle line, and a solid bottom bar.

Handwriting practice line with a solid green top bar, a dashed middle line, and a solid bottom bar.

Handwriting practice line with a solid green top bar, a dashed middle line, and a solid bottom bar.

Handwriting practice line with a solid green top bar, a dashed middle line, and a solid bottom bar.

Handwriting practice line with a solid green top bar, a dashed middle line, and a solid bottom bar.



Metinleri 3 kez oku. Her okuduğunda bir gülen yüz boya.

EKLE

Ela  ekle.

Ela 2  ekle.

Ela  ekle.



Ela al 2 ak .

Al lale 2 ak .

Kalk lale al ak .





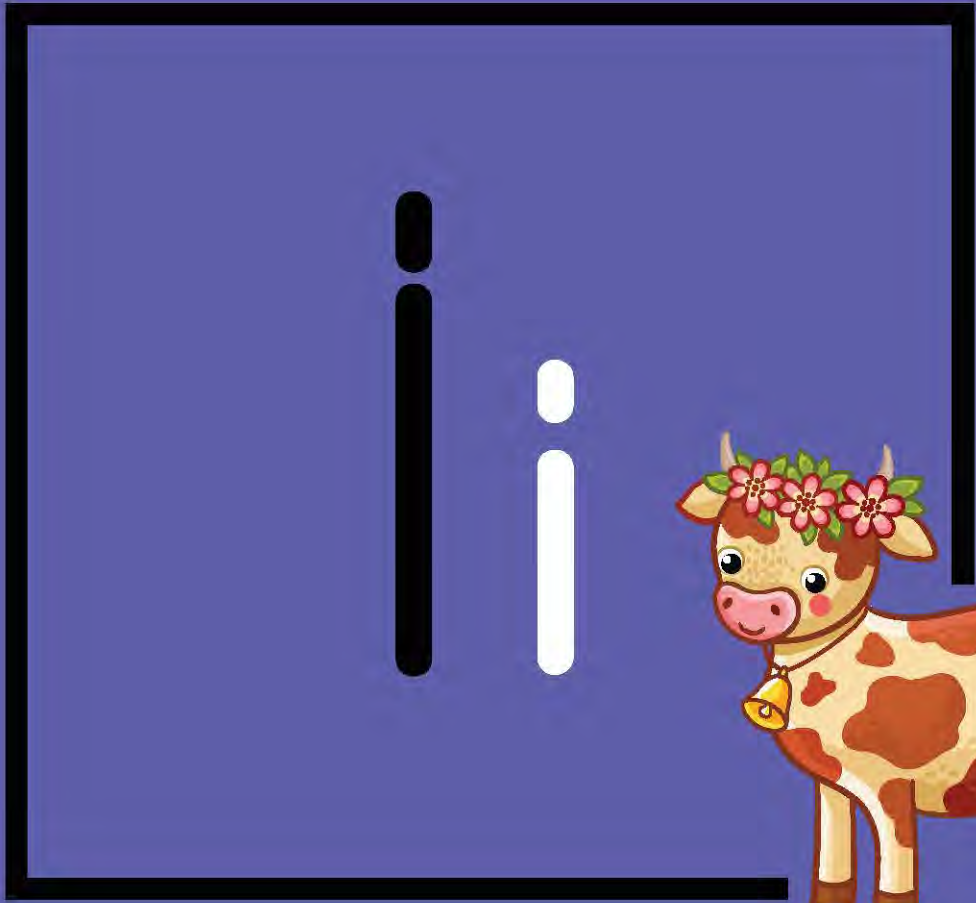



Resimlere bak, "i" sesi ile başlıyorsa gülen yüzü, i sesi ile başlamıyorsa ağlayan yüzü boya.

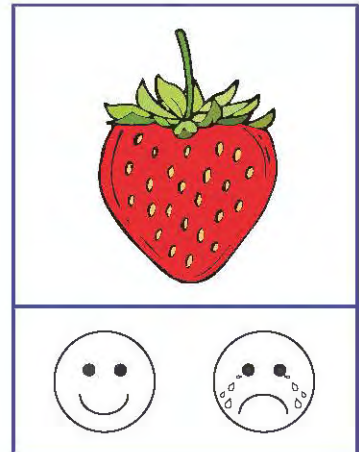
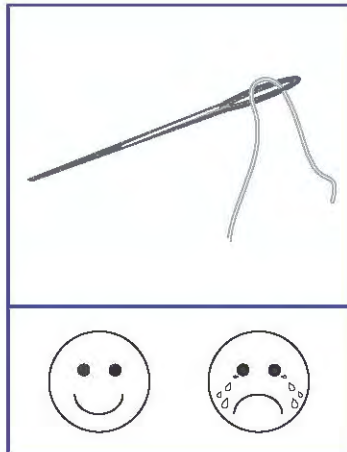
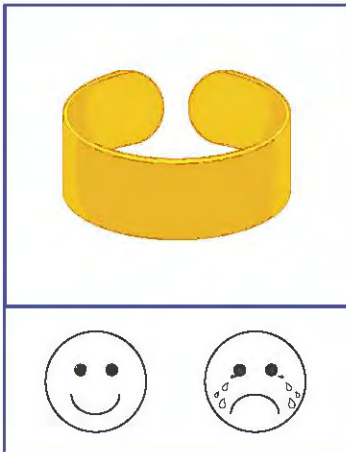
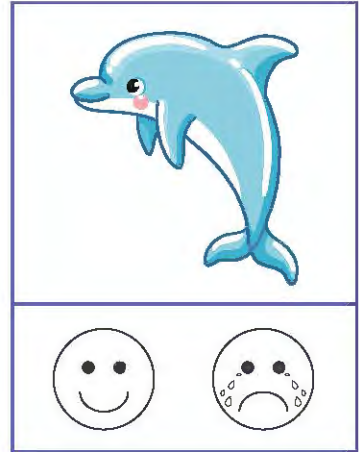
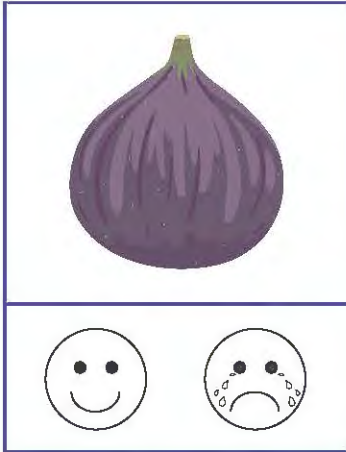
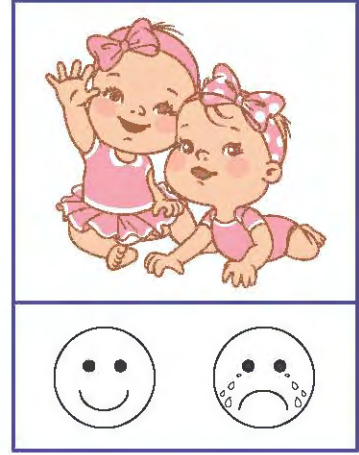
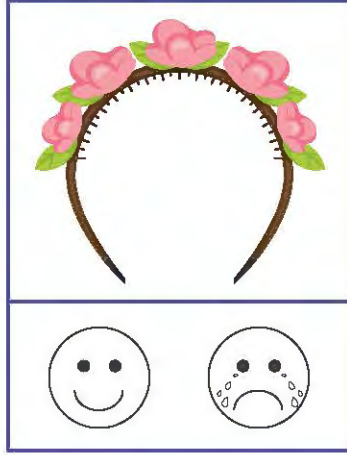
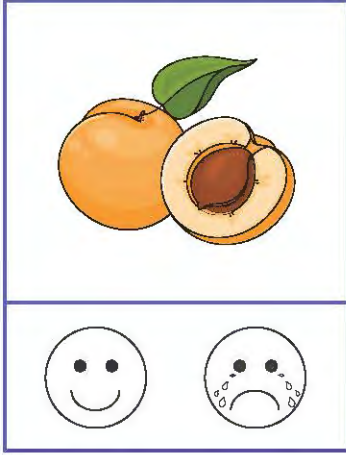



i sesini öğreniyorum.

Aşağıdaki her satırda "i" sesi ile biten bir resim vardır. Bu resmi bul ve işaretle.

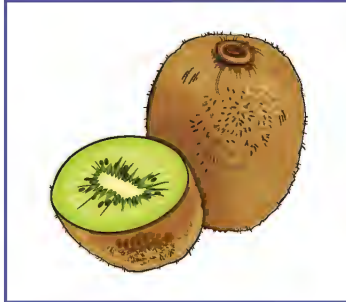
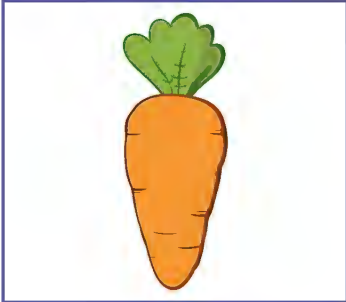



Aşağıdaki resimlerde yer alan varlıkların isimlerini söyle. Bu isimlerin hangi sesle başladığını söyle.

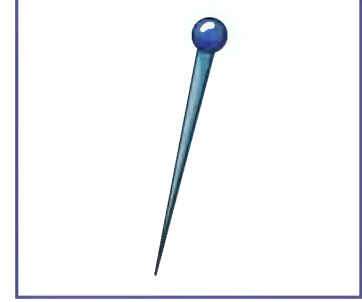
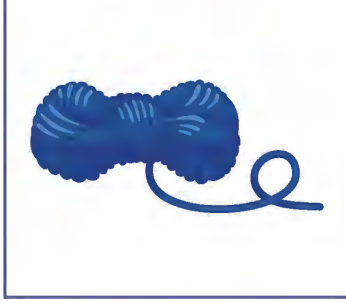

Aşağıdaki resimlerde yer alan varlıkların isimlerini söyle. Bu isimlerin hangi sesle bittiğini söyle.





sesini öğreniyorum.

Sesi oku.



"i" harflerini bularak boya.

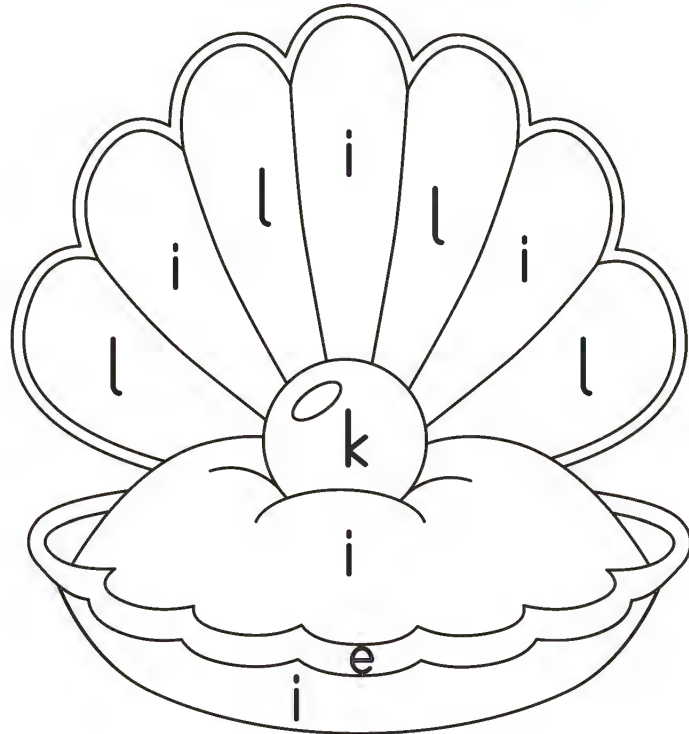

Oku çevir, "i" sesi ile başlayan resim geldiğinde piyonunu iki kare ilerlet. "ı" sesi ile başlayan resim gelmezse piyonunu bir kare geri çek. Yolun sonuna ilk gelen kazanır. Bu oyun iki kişi ile oynanır.



Birinci Oyuncu İkinci Oyuncu

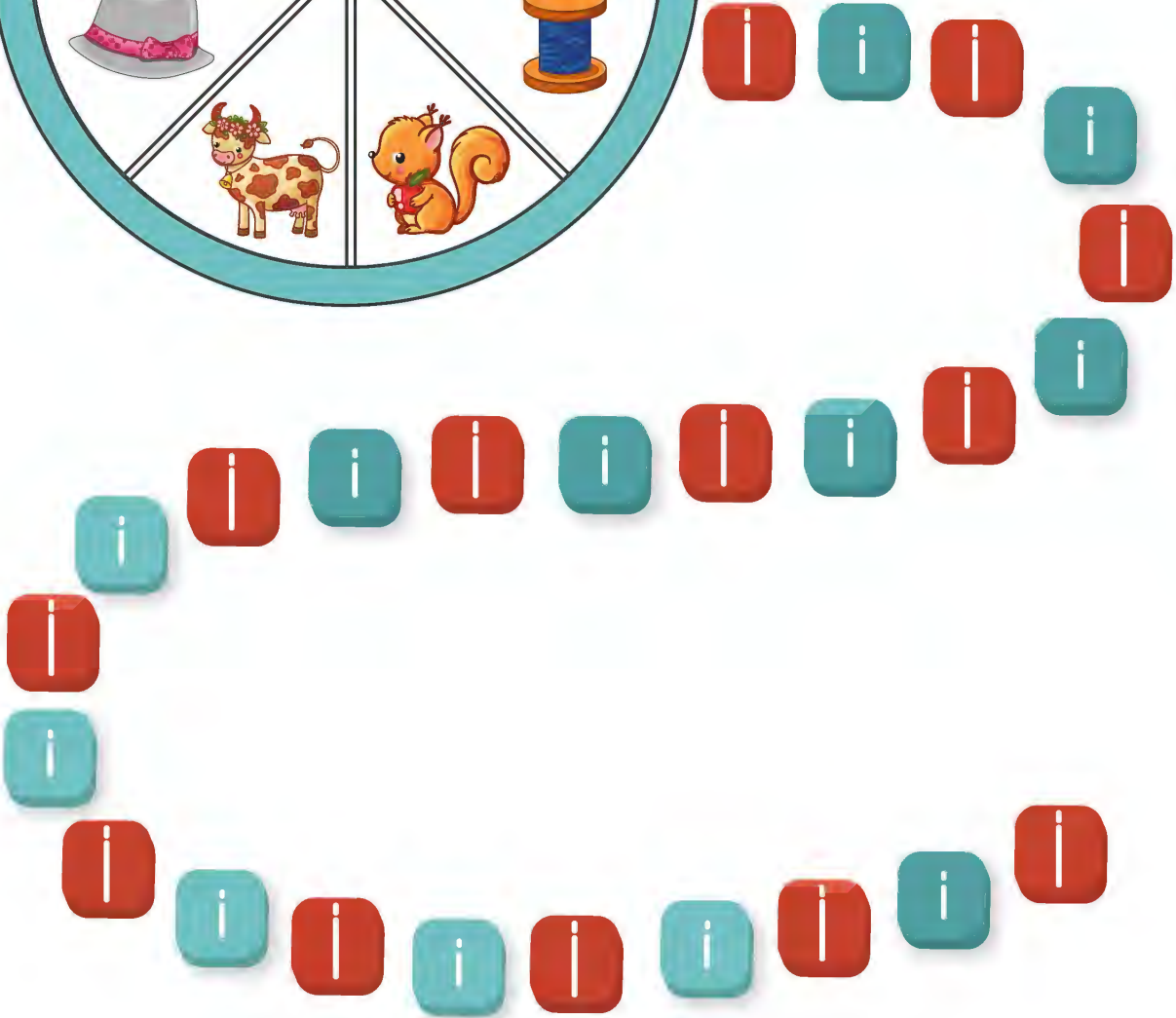



"i" harflerini bularak boya.

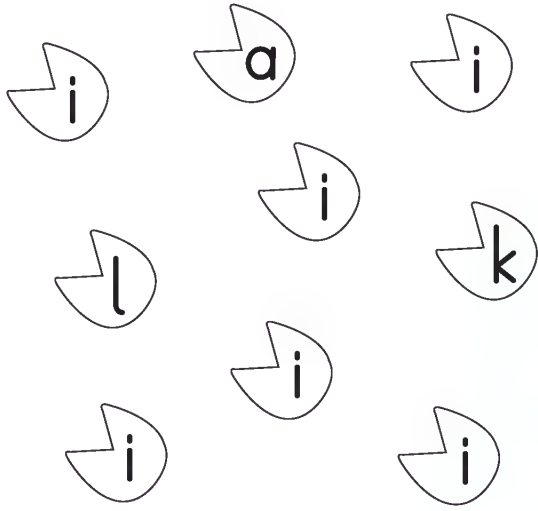

Karıncanın sandviçe ulaşması için "i" harflerini takip etmesi gerekiyor. "i" harflerini bularak karıncayı sandviçe götür.

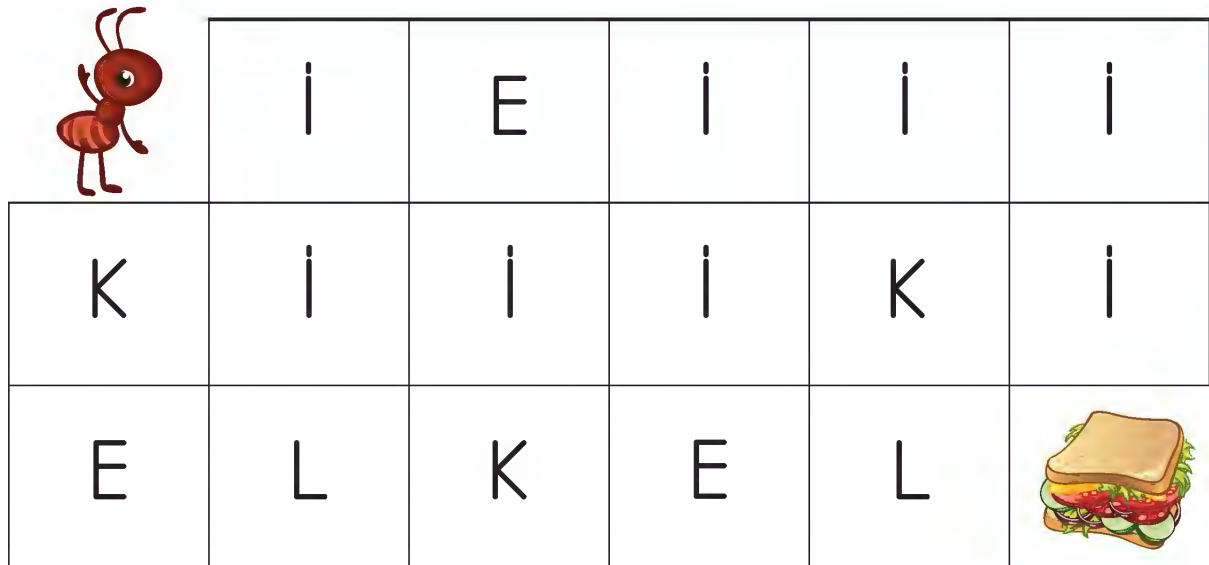



Sözcüklerde yer alan "i" harflerini bulup işaretle.

tişört



kedi



çekiç



kibrit



kitap



inek



Sözcüklerde yer alan "İ" harflerini bulup işaretle.

ÇİLEK



CEVİZ



LİMON

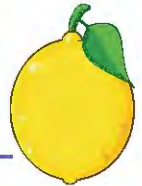

GEMİ



BİSİKLET



SİNEK





Handwritten text on a blue banner, likely a page title or theme.

Sesi oku.

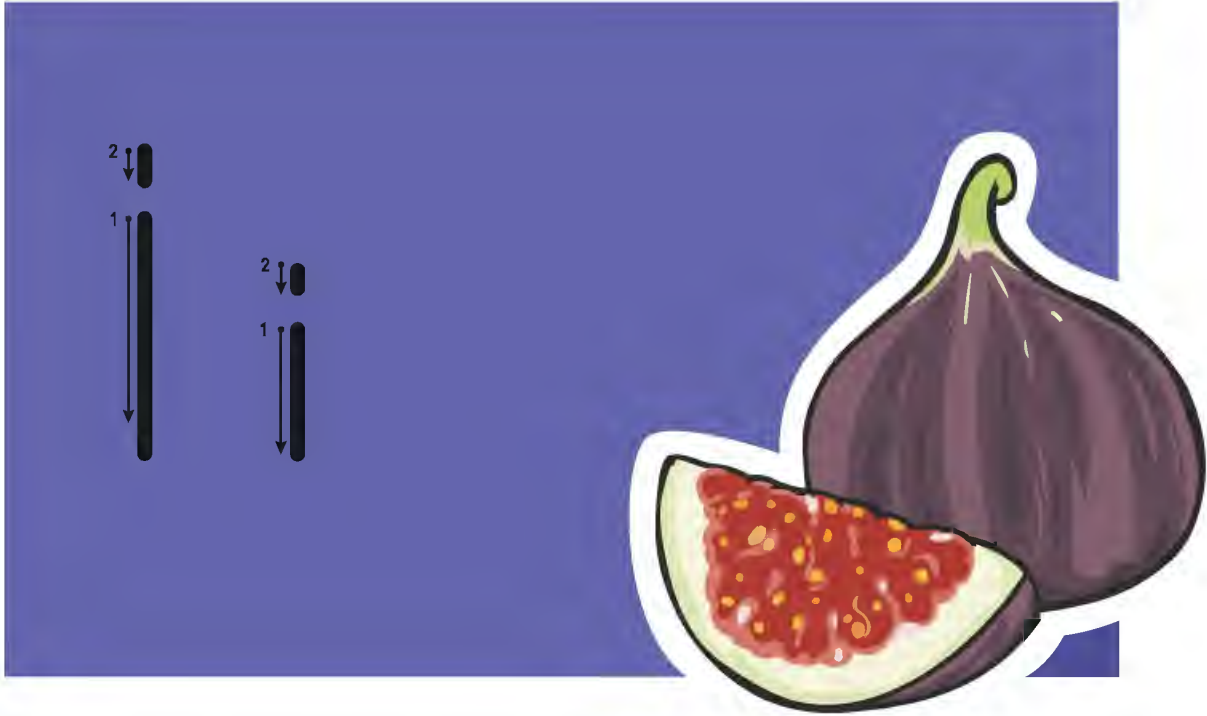

Yaz.

Five horizontal writing lines for practicing the letter 'i'. Each line consists of a top solid line, a middle dashed line, and a bottom solid line. A vertical line is drawn on the left side of each line, starting from the top solid line, going down to the middle dashed line, and then ending with a small dot above the middle dashed line. This pattern is repeated across all five lines.



Yaz.

i

i

i

i



Söylediğim sesi yaz.



Hece ve sözcükleri oku ve yaz.



Hece ve sözcükleri oku. Okuduğun hece ve sözcüğün yanındaki yıldızı boya.

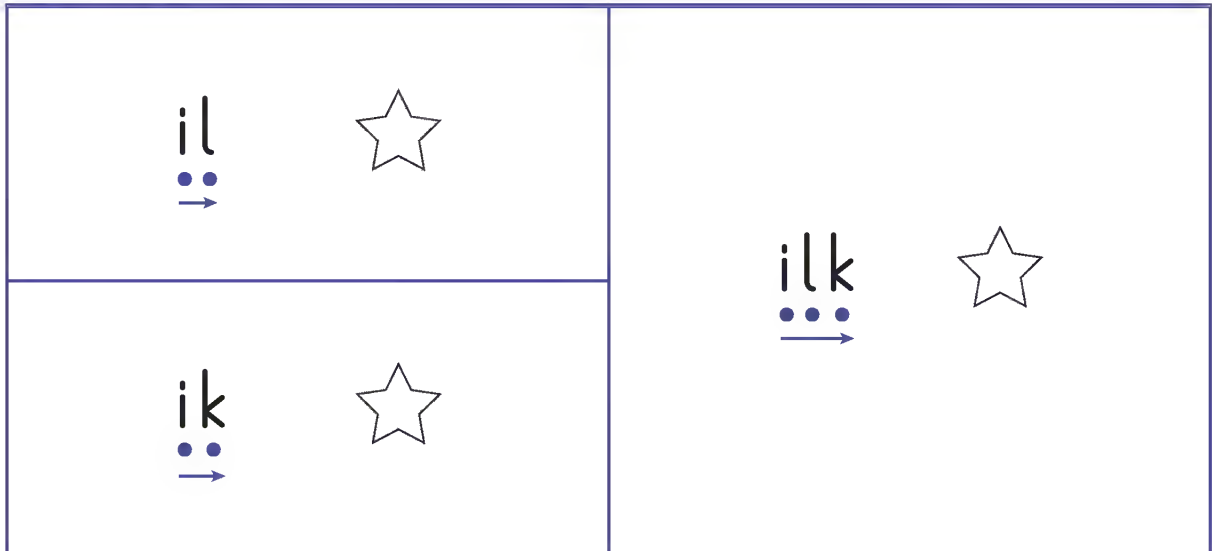



Heceleri oku ve yaz.

l i li



Blank writing line for the word 'li'.

k i ki



Blank writing line for the word 'ki'.

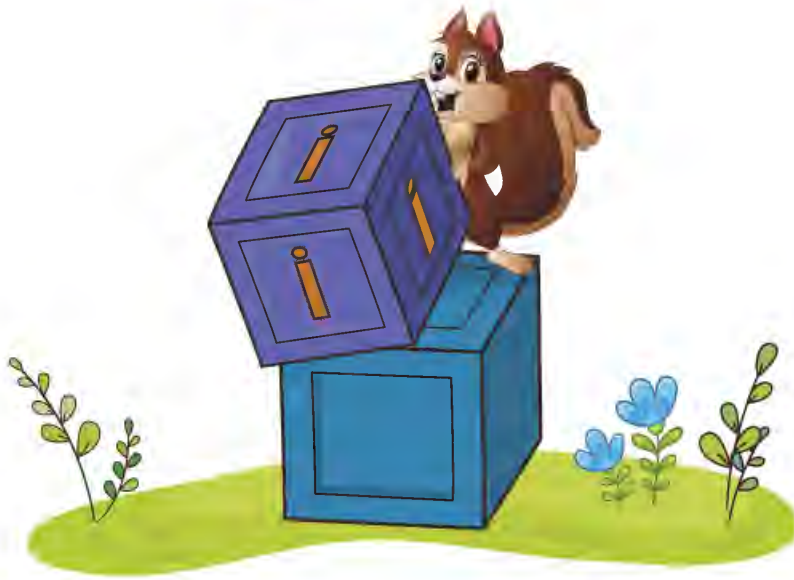
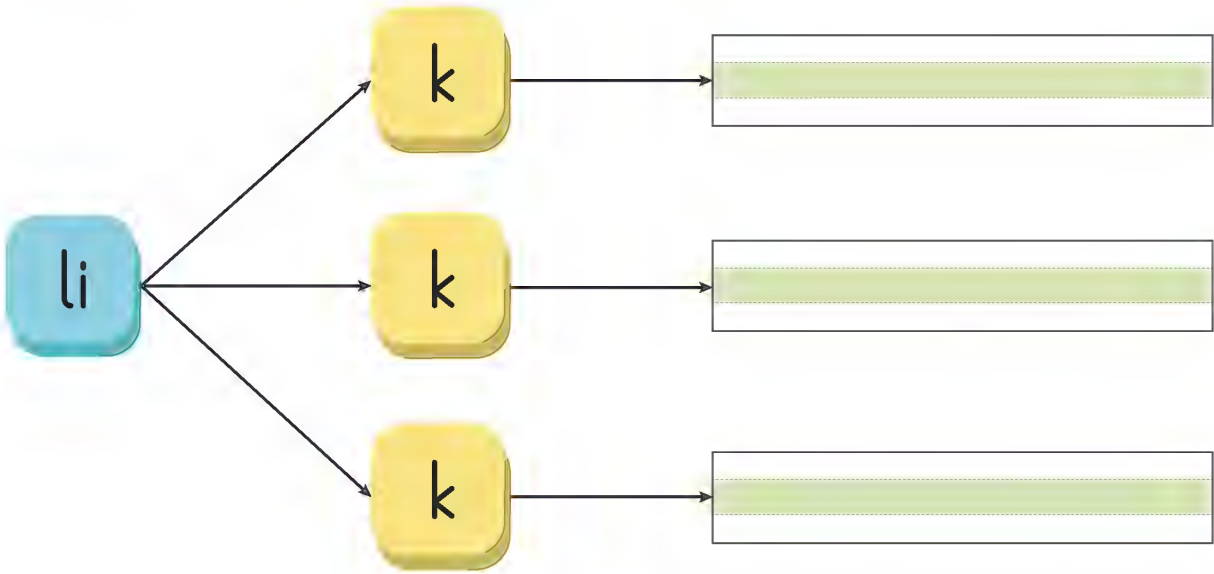



okunu öğreniyorum.

Hece ve sözcükleri oku ve yaz.

ki

k

k

k

ki

l

l

l



Heceleri oku ve yaz.

A diagram illustrating the decomposition of the syllable 'li'. On the left, a blue rounded square contains the letters 'li'. Three arrows point from this square to three yellow rounded squares, each containing the letter 'l'. From each 'l' square, an arrow points to a horizontal writing line with a green shaded top section and a white bottom section, intended for practicing the letter 'l'.

Hece ve sözcükleri oku. Okuduğun hece ve sözcüğün yanındaki yıldızı boya.

li ☆ →	kil ☆ →
ki ☆ →	lil ☆ →
lik ☆ →	kik ☆ →



Baştaki hece ve sözcükleri oku. Her satırda farklı olan hece ve sözcükleri bul.

ilk	il	ilk	ik	ak	ilk	ilk	ilk	ilk
kil	kil	kil	kil	il	lil	kil	kil	kil
ki	il	ki	ki	ki	ki	al	ki	ki

Söylediğim heceyi yaz.



Aynı heceleri eşle.

ki	ik
li	LE
KA	EL
le	Li
İK	Kİ
el	ka

Söylediğim heceyi yaz.



Sözcükleri oku ve yaz.

i ki iki

e li eli

el li elli

ke ki keki

ke li keli

il ke ilke

i ki li ikili

a i le aile

i lik le ilikle



Sözcükleri oku ve yaz.

la

ik

ik

ik

i

lik

lik

lik



sesini öğreniyorum.

Sözcükleri oku ve yaz.

ke

kik

kik

kik

kil

li

li

li

kek

lik

lik

lik

Each of the above words is followed by three horizontal writing lines: a top line, a middle dashed line, and a bottom line.



Sözcükleri oku. Okuduğun sözcüğün yanındaki yıldızı boya.

iki •• →	☆	ikili ••• →	☆
eli •• →	☆	ilik •• →	☆
Ali •• →	☆	ilikle ••• →	☆
ile •• →	☆	kekik •• →	☆
keki •• →	☆	killi •• →	☆
keli •• →	☆	keklik •• →	☆
ilke •• →	☆	ilk • →	☆
laik •• →	☆	aile ••• →	☆

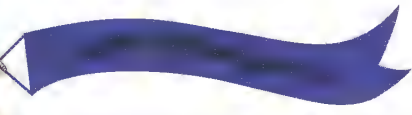

Bak ve yaz.	Kapat ve yaz.	Aç, karşılaştır yanlışsa düzelt ve yaz. Oku.
iki _____	_____	_____
eli _____	_____	_____
Ali _____	_____	_____
ile _____	_____	_____
keki _____	_____	_____
keli _____	_____	_____
ilke _____	_____	_____
laik _____	_____	_____
ikili _____	_____	_____
ilik _____	_____	_____



Sıra ile oku.



i
il
ili
ilik
ilikle



i
ik
iki
ikili



ke
kek
kekli
keklik



Sonu "ki" ile biteni işaretle.

ki

2



Sonu "li" ile biteni işaretle.



li



Sonu "lik" ile biteni işaretle.



lik

Sonu "kik" ile biteni işaretle.

kik





Aşağıdaki boşluklara "i" harflerini yaz ve sözcüğü oku.

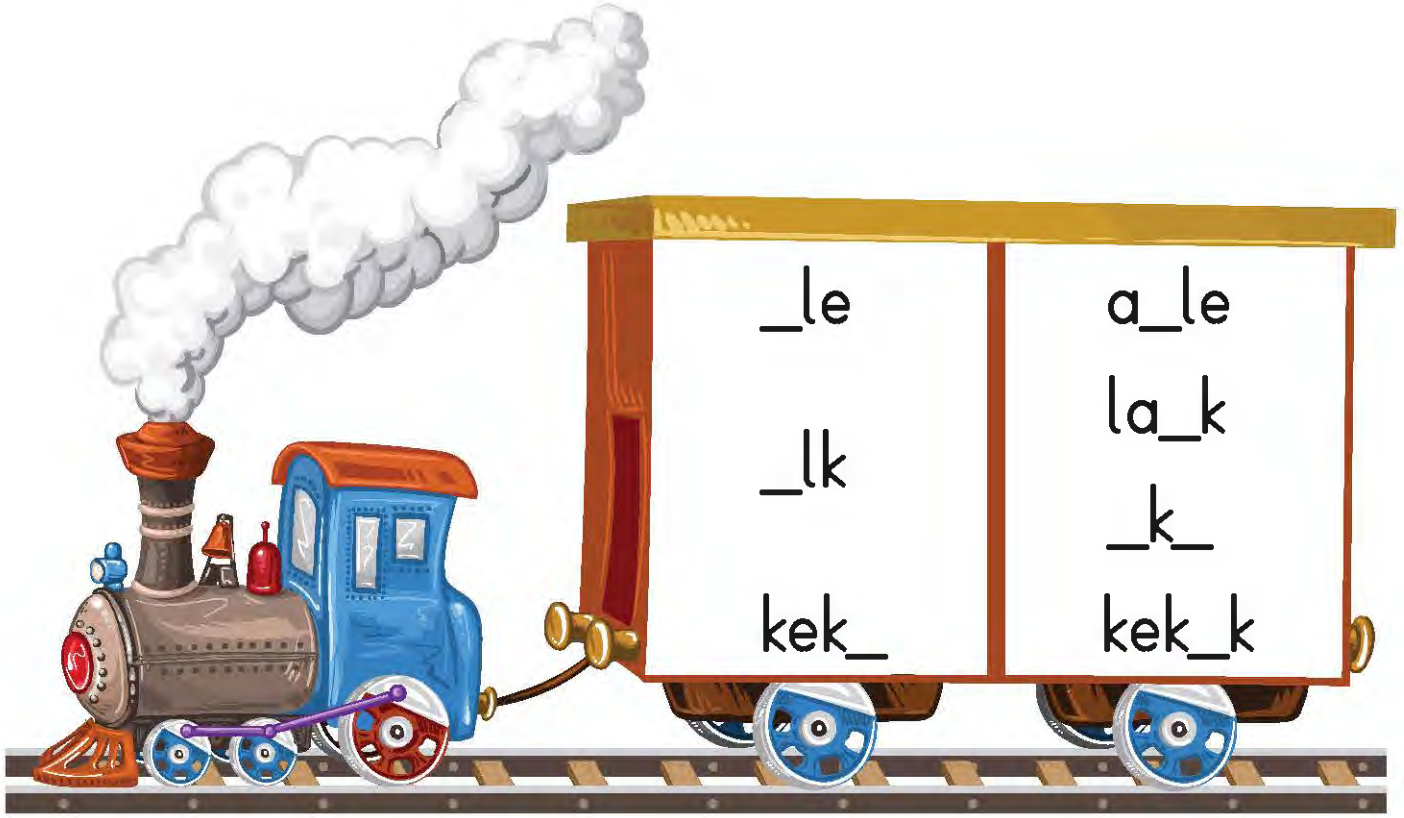

Söylediğim sözcükleri yaz.



sesini öğreniyorum.

Sözcüğü oku ve uygun resmi bul.

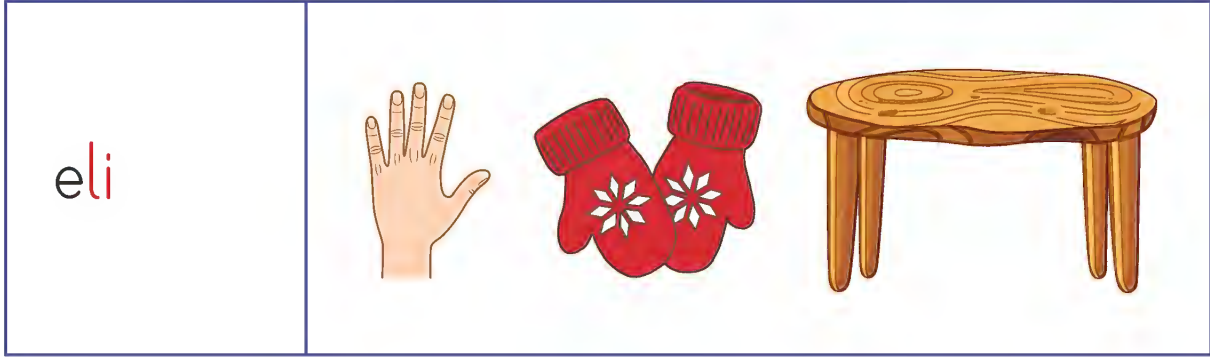
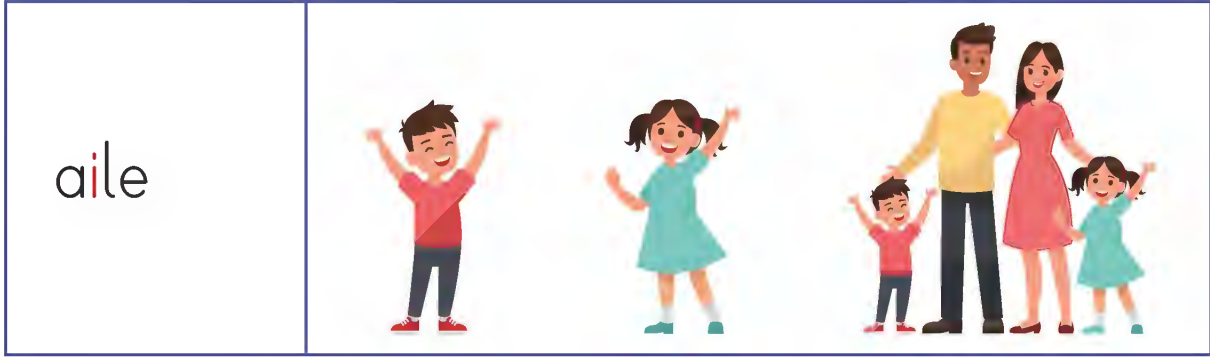



Cümleleri oku. Okuduğun cümlelerin yanındaki yıldızı boya.

Ela ile Lale el ele.



Lale kile  ekle.



İki kek al.



Ali  kekik ekle.



Lale keklik al.





Cümleleri yaz. Cümleleri yazdıktan sonra kutucuğu işaretle.

Ela ile Lale el ele.

Lale kile  ekle.

İki kek al.

Ali  kekik ekle.



Sıra ile oku.

Ali

Ali kil

Ali kil ile

Ali kil ile iki

Ali kil ile iki kale

Ali kil ile iki kale 





Cümleyi oku ve öğretmenin sorduğu sorunun cevabını alttaki kutucukta işaretle.

Ela ile Lale el ele.

Kim Lale ile el ele?



Lale
Ela
Ali

Lale kile  ekle.

Lale suyu neye eklesin?



keke
kile
ele



Cümleyi oku ve öğretmenin sorduğu sorunun cevabını alttaki kutucukta işaretle.

Ali iki kek al.

Ali iki ne alsın?



el
kale
kek

Ali kil ile kale yap.

Ali ne ile kale yapsın?



kil
el
kek



Cümleleri oku. Okuduğun cümle ile ilgili resmin bulunduğu kutucuğa cümlenin numarasını yaz.

1. İki kek al.
2. Ela ile Lale el ele.
3. Lale elek ile ele.
4. Ali ikili kale al.





Metinleri 3 kez oku. Her okuduğunda bir gülen yüz boya.

KALE

Ali kile  ekle.

Ali kille kale 

Ali kille iki kale 



KEK

Lale  ele.

Lale kalk elek ile  ele.

Lale keke  ekle.

Lale kek 



Nn

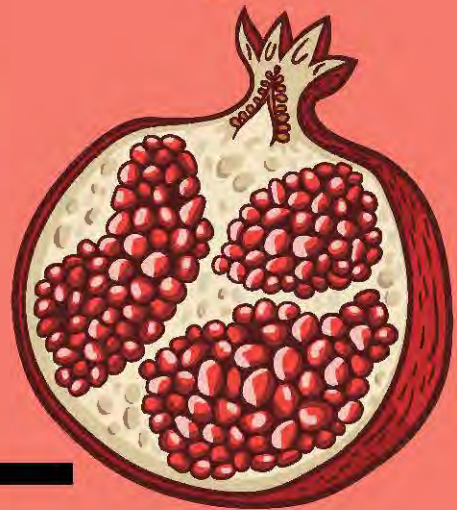

Resimlere bak, "n" sesi ile başlayanları altlarındaki kutuya işaretle ve söyle.

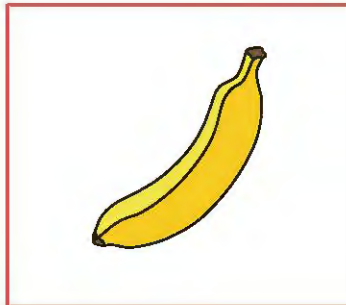
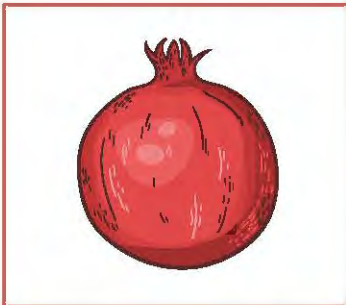
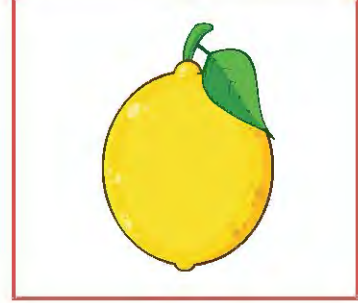



N sesini öğreniyorum.

Aşağıdaki her satırda "n" sesi ile biten bir resim vardır. Bu resmi işaretleyin ve söyleyin.

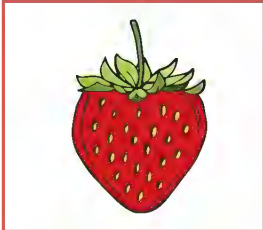

Sesi oku.

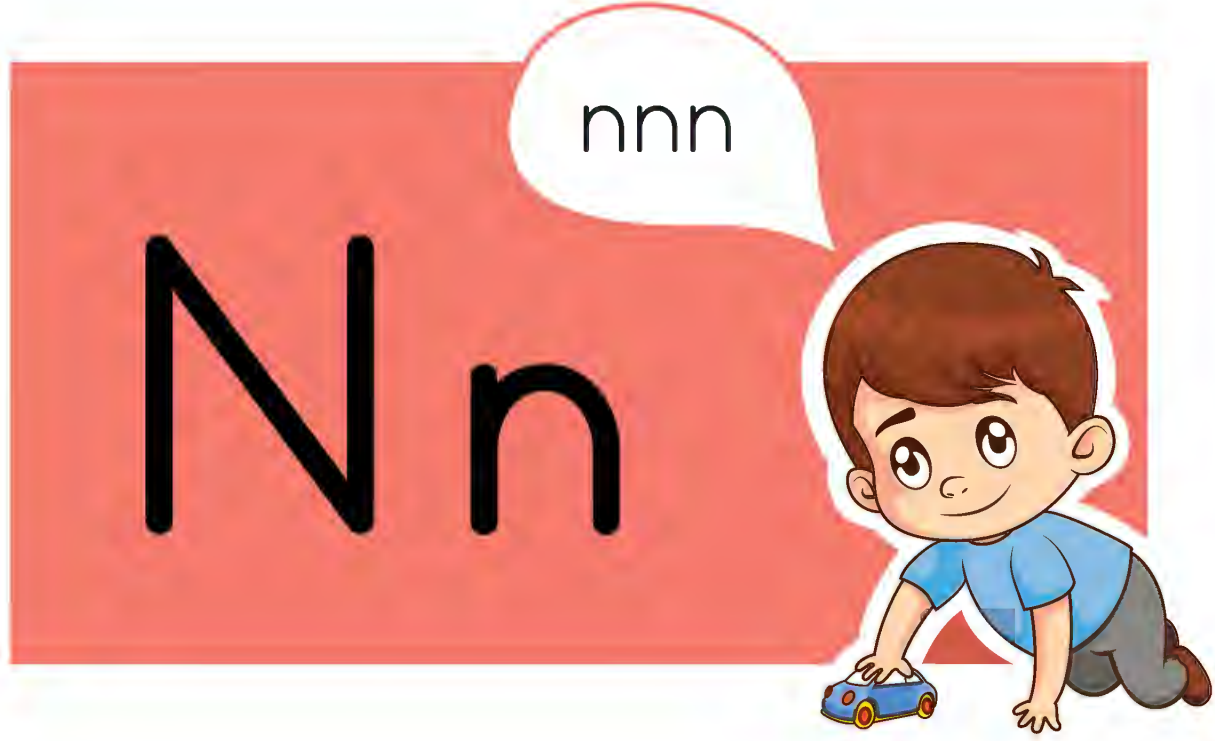

Resimlere bak, "n" harflerini "n" harfi ile başlayan resimlerle eşle.

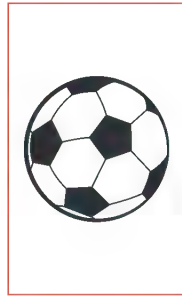
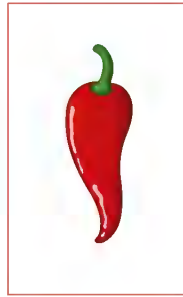
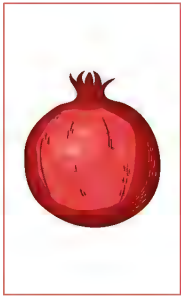

n n n



N sesini öğreniyorum.

"N" harflerini izleyerek topu çocuğa götür.

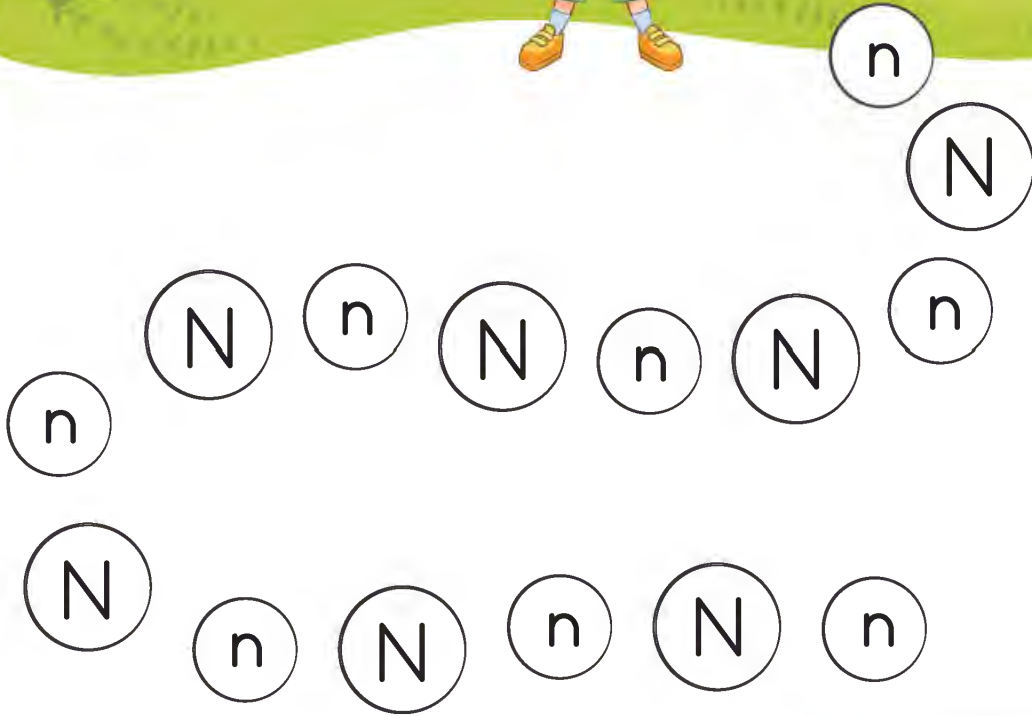

"n" harflerini bularak boya.

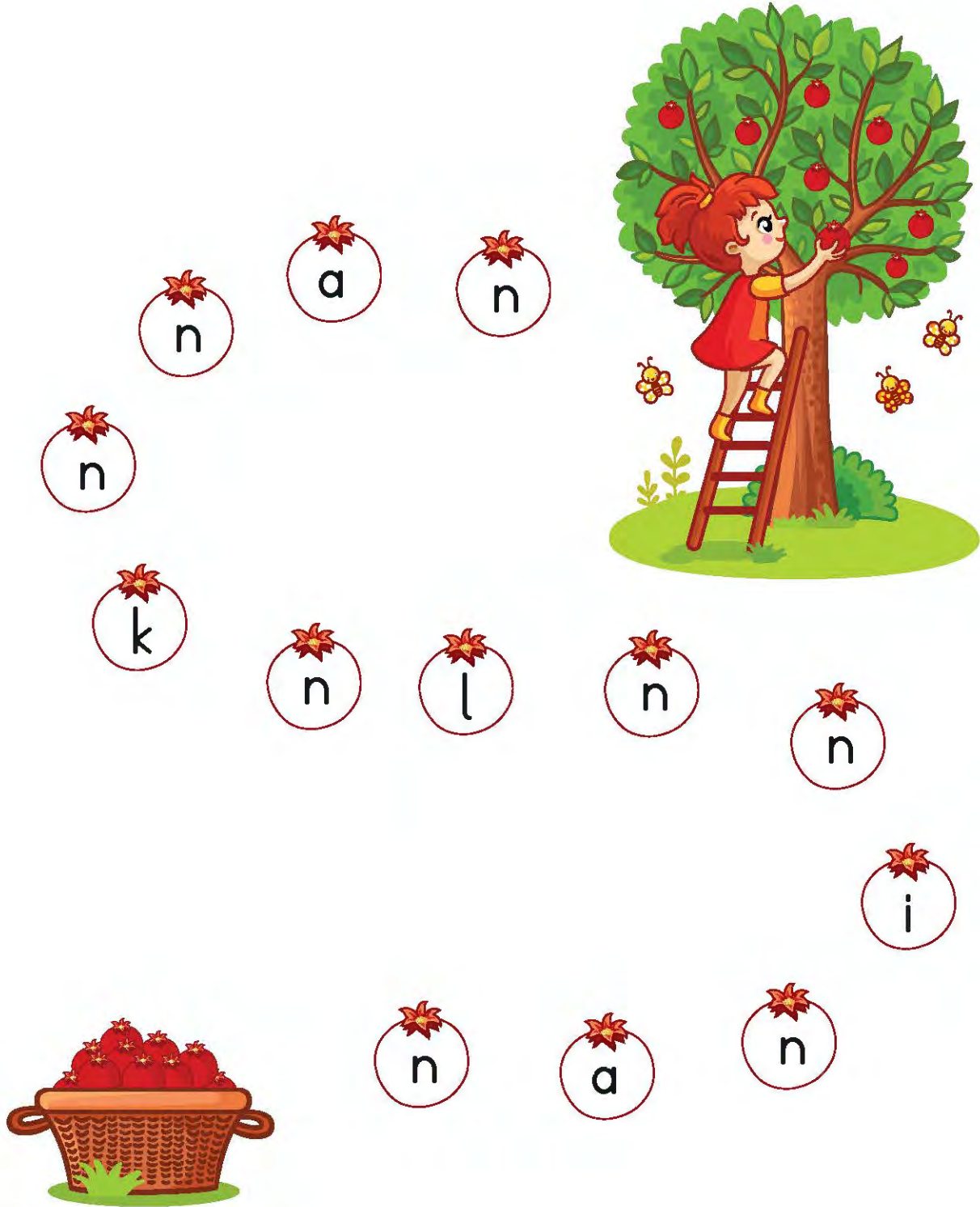



N sesini öğreniyorum.

“N” harfi olan yumakları boya.

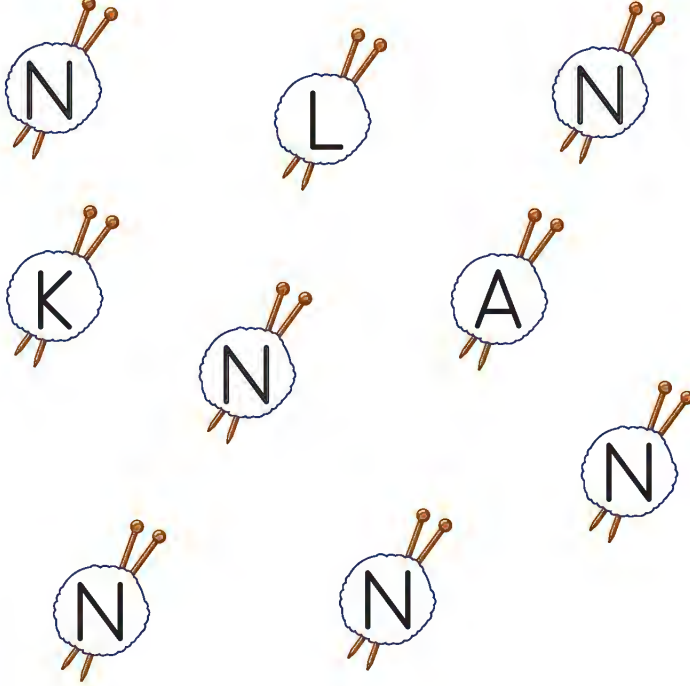

Aynı harfleri eşleştir ve oku.

a

N

E

l

k

n

L

A

K

e



Sözcüklerde yer alan "n" sesini bulup işaretle.

sabun



rende



lahana



limonata



yılan



incir

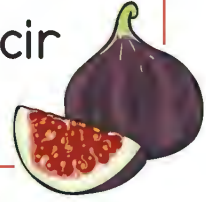

Aşağıdaki sözcüklerde yer alan "N" sesini bulup işaretle.

FINDIK



MANTAR



MANDALİNA



KAVUN



KESTANE

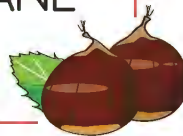

KARNABAHAAR





N sesini öğreniyorum.

Sesi oku.



Yaz.

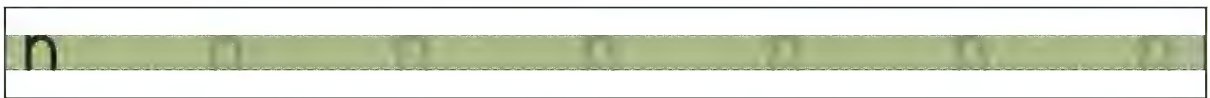
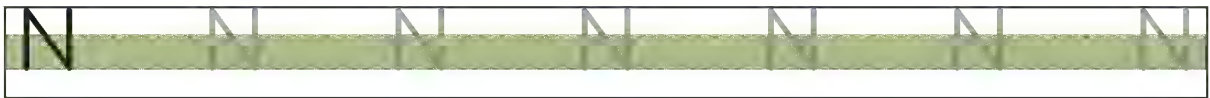
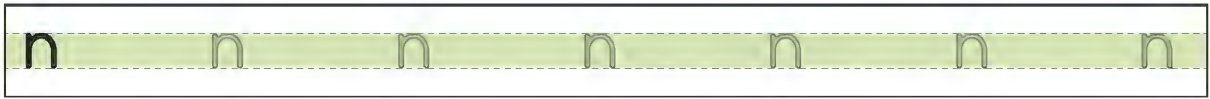
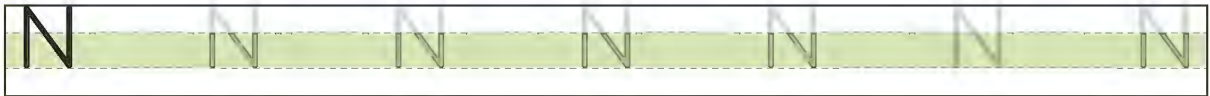

Yaz.

N

n

N

n



Söylediğim sesi yaz.



N sesini öğreniyorum.

Hece ve sözcükleri oku ve yaz.

e n en →

a n an →

i n in →

Hece ve sözcükleri oku ve yaz.

la le ka n →

le →

ka →

Heceleri oku ve yaz.

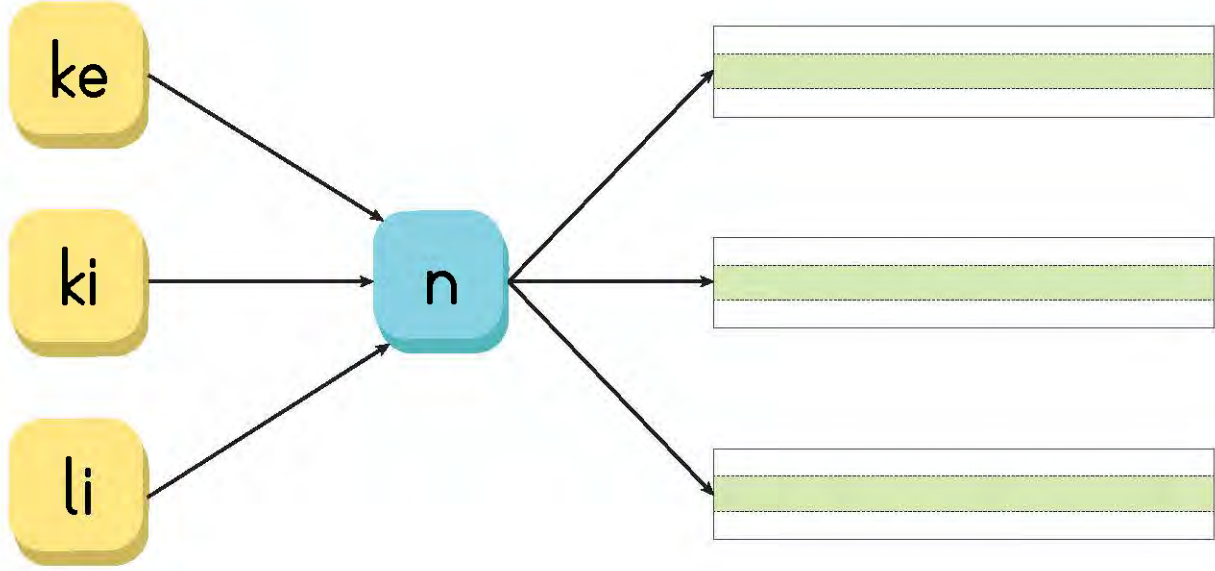

Hece ve sözcükleri oku. Okuduğun hece ve sözcüğün yanındaki yıldızı boya.

en •• →	☆	len ••• →	☆
an •• →	☆	ken ••• →	☆
in •• →	☆	kin ••• →	☆
kan ••• →	☆	lin ••• →	☆



N sesini öğreniyorum.

Baştaki hece ve sözcükleri oku. Her satırda farklı olan hece ve sözcükleri bul.

en	en	en	an	in	en	en	en	en
kan	kan	kan	kan	kan	kin	kan	kin	kan
len	len	len	len	len	lin	lin	len	len
an	an	an	an	en	an	in	an	an

Söylediğim hece ve sözcükleri yaz.

--

--

--

--

Heceleri oku ve yaz.



Hece ve sözcükleri oku ve yaz.

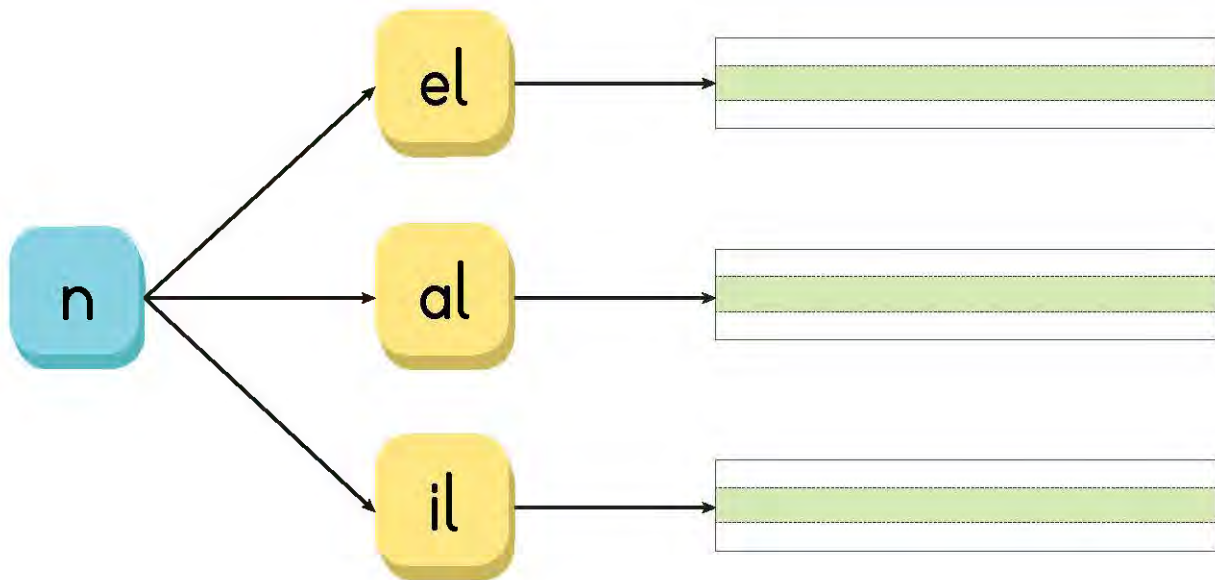



N sesini öğreniyorum.

Heceleri oku ve yaz.

A diagram showing the letter 'n' in a blue box on the left. Three arrows point from 'n' to three yellow boxes containing the syllables 'ek', 'ak', and 'an'. To the right of each yellow box is a horizontal writing line with a green top bar, a dashed middle line, and a white bottom bar.

Hece ve sözcükleri oku. Okuduğun hece ve sözcüğün yanındaki yıldızı boya.

ne •• →	☆	nal ••• →	☆
na •• →	☆	nek ••• →	☆
ni •• →	☆	nak ••• →	☆
nel ••• →	☆	nan ••• →	☆

Tabloda yer alan hece ve sözcükleri soldan sağa, yukarıdan aşağıya doğru oku.

na	na	na	na
ne	ne	ne	ne
ni	ni	ni	ni
nal	nal	nal	nal

nel	nel	nel	nel
nek	nek	nek	nek
nak	nak	nak	nak
nan	nan	nan	nan



N sesini öğreniyorum.

Başlangıç noktasından ilerleyerek heceleri hızlı oku. Her okuyuşundan sonra bir yıldız boya.

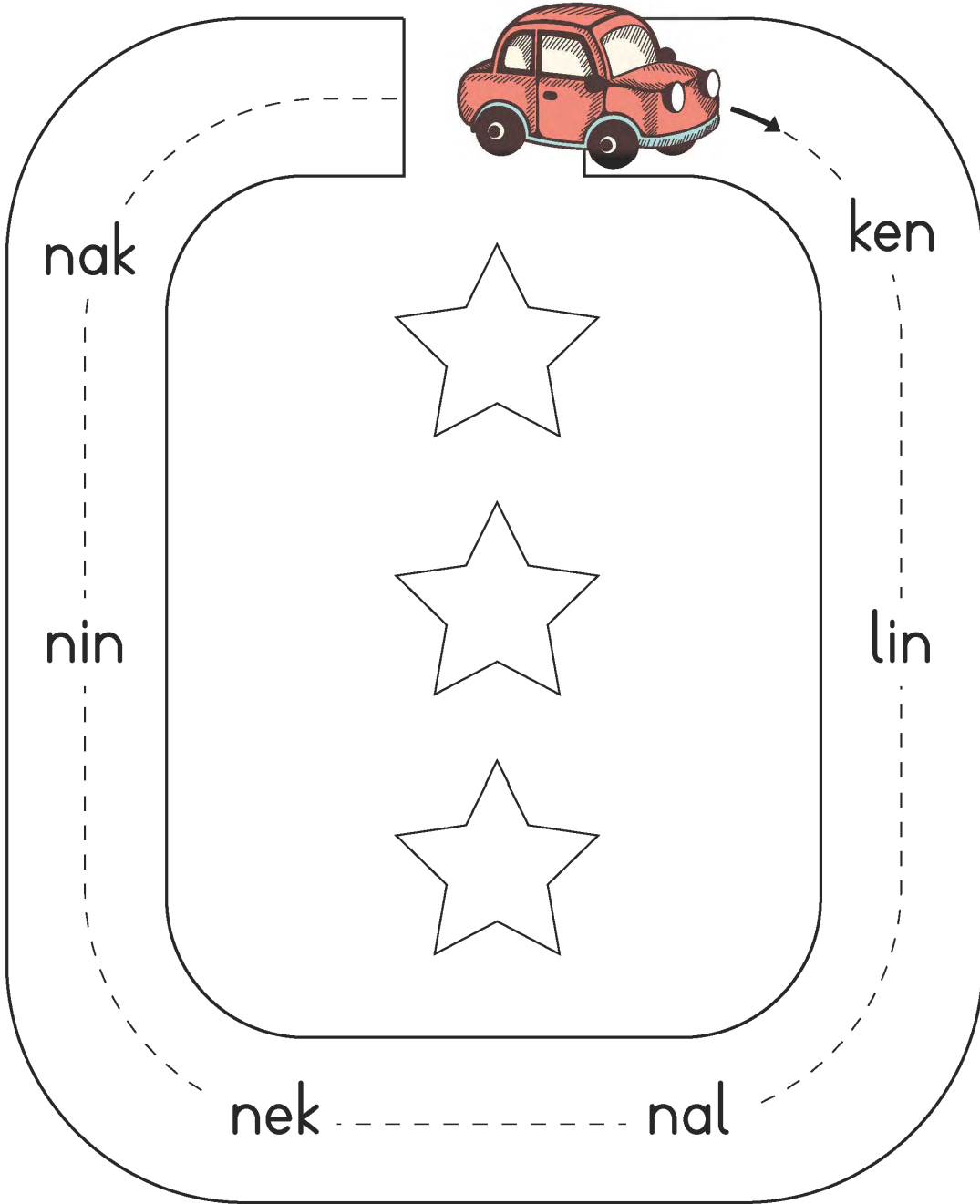

Sözcükleri oku ve yaz.

en li enli



an la anla



nane nane



nal nal



Nil Nil



a i len ailen





N sesini öğreniyorum.

Sözcükleri oku ve yaz.

ni

na

an

ne

i

nal

nek

lan

Aşağıdaki sözcükleri oku ve yaz.

e kin ekin →

İ nal İnal →

ka nal kanal →

anne anne →

en li entli →

nal la nalla →



N sesini öğreniyorum.

Sözcükleri oku. Okuduğun sözcüğün yanındaki yıldızı boya.

anne	☆	eline	☆
enli	☆	alana	☆
anla	☆	naneli	☆
nine	☆	nineni	☆
nane	☆	kekine	☆
kene	☆	annene	☆

Sözcükleri oku. Okuduğun sözcüğün yanındaki yıldızı boya.

nal →	☆	ana →	☆
Nil →	☆	kanal →	☆
ekin →	☆	nakil →	☆
İnal →	☆	ninni →	☆
İnek →	☆	nalla →	☆
ilan →	☆	ailen →	☆



N sesini öğreniyorum.

Oku.	Bak ve yaz.	Hecelerine ayır.	Tekrar oku. ve ✓ koy.
anne	-----	anne	anne
enli	-----	enli	enli
anla	-----	anla	anla
nine	-----	nine	nine
nane	-----	nane	nane
eline	-----	eline	eline
alana	-----	alana	alana
naneli	-----	naneli	naneli
nineni	-----	nineni	nineni
kekine	-----	kekine	kekine

Sözcüklerin yazılı olduğu kartları bir torbaya koy ve bir resimli kart seç. Sıran geldiğinde torbadan bir sözcük seç ve oku. Resimli kartında torbadan çıkan sözcüğün resmi varsa o resmin üstünü kapat. Resimli karttaki tüm resimleri önce kapatan kazanır.

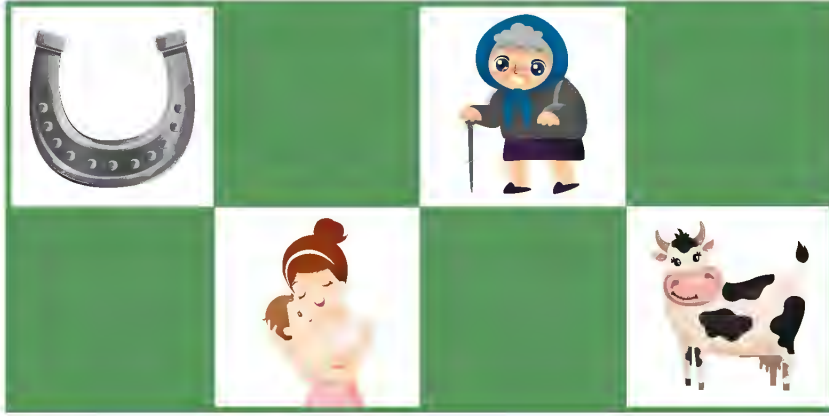

Nal	Nine
Anne	İnek



Ekin	İlan
Anne	Kek



Nane	Aile
Anne	Nal



N sesini öğreniyorum.

Oku çevir. Gelen heceyi aşağıda verilen sözcük kartında bulunan hecelerle birleştirerek sözcük oluştur ve üstünü kapat. Kartaki tüm hecelerden sözcük yaptığında oyun biter.

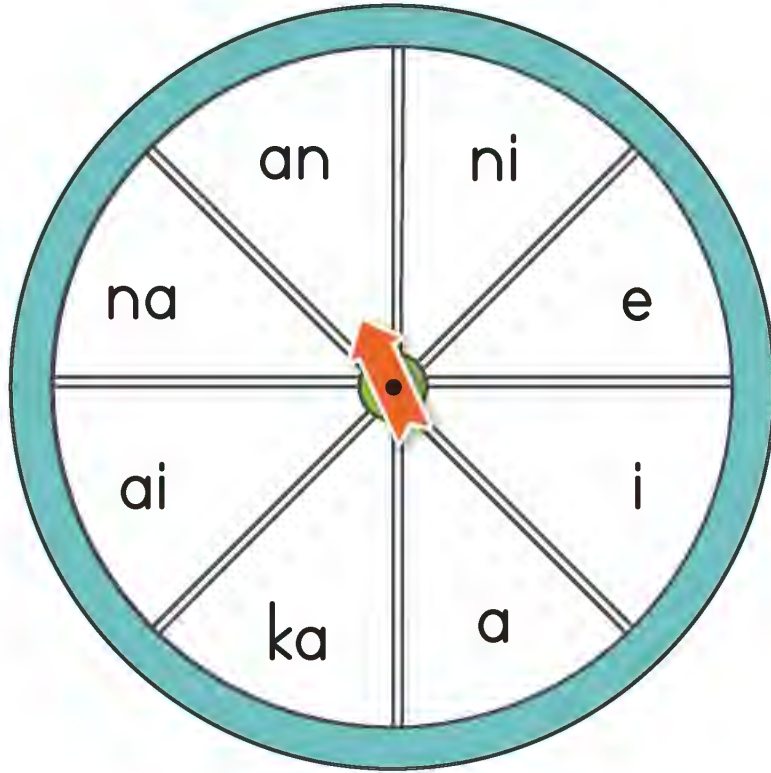

ne	kin	nek
le	nal	nik
lan	la	li



Alttaki kutularda yer alan sözcüklere bakarak resimlerin isimlerini boş bırakılan yere yaz.

ekin

inek

nine

nal

e



n



i



n



Söylediğim sözcükleri yaz.



N sesini öğreniyorum.

Cümleleri oku. Okuduğun cümlenin yanındaki yıldızı boya.

Nine ekin ek.
→



İnal  nalla.
→



Anne nane al.
→



Nil iki naneli kek ekle.
→



Cümleri yaz. Cümleri yazdıktan sonra kutucuğu işaretle.

Nine ekin ek.

İnal  nalla.

Anne nane al.

Nil iki naneli kek ekle.



N sesini öğreniyorum.

Resimden yararlanarak boşluğu doldur.

----- nane al.



Nil ----- ekle.



Nine ----- elle.



İnal ----- ek.



Metinleri 3 kez oku. Her okuduğunda bir gülen yüz boya.



Lale  al.

Al Lale  al.

Annenin eline  al.

Ninenin eline  al.



KANAL

Ali alana kanal ekle.

Ali kille kanal ekle.

Kanala  ekle.



Kaynakça

- Allman, B., (2005), *Spell and Writing Connecting School and Home, Grade 2*, USA: Evan-Moor.
- Allman, B., (2005), *Spell and Writing Connecting School and Home, Grade 3*, USA: Evan-Moor.
- Braun, H., (2018), *Learn to Read Activity Book: 101 Fun Lessons To Teach Your Child To Read* Paperback, CA: Zephyros Press.
- Doğanay-Bilgi, A. (2016), "Zihinsel Engellilere Okuma Yazma Öncesi Becerilerin Kazandırılması Ders Notları" Ankara: Gazi Üniversitesi.
- Doğanay-Bilgi, A. (2017), *Öğrenme Güçlüğü Sınıf İçerisi Destek Kitabı* İli, Okuma Yazmada Öğretimsel Stratejiler, E. R. Özmen(Ed.) Ankara: Eğiten Kitap.
- Doğanay-Bilgi, A., & Güzel-Özmen, R. (2010), *Okuma Öğretimi*, I. H. Diken (Ed.), *İlköğretimde Kaynaştırma* (sf. 361-401). Ankara: Pegem Yayınevi.
- Ellen-Moore, J., (1979), *Sequencing Cut and Paste Activities Grades K-1*, USA: Evan-Moor.
- Ellen-Moore, J., & Evans, J., (1979), *Read, Think Cut and Paste Grade 1-3*, USA: Evan-Moor.
- Ellen-Moore, J., & Evans, J., (1983), *Short Story Sequencing Grade 1-2*, USA: Evan-Moor.
- Fleming, M., (2010), *Sequencing Practice Mini-books Grades K-1*, New York: Scholastic.
- MEB (2018), *Orta-Ağır Zihinsel Engeli ve Otizm Spektrum Bozukluğu Olan Öğrenciler İçin Okuma Yazma Öğretim Programı* I. Kademe, Ankara: Millî Eğitim Bakanlığı Yayınları.
- Okuma Yazma Seti, (2017), İzmir: TÜDEM Yayıncılık.
- Özer, S., Kapucu, A., (2013), *Birlik Birlik Okulda*, Ankara: ODTÜ Yayıncılık.
- Özmen, E. R. (2016), "Okuma Yazma Öğretimi Lisans Ders Notları" Ankara: Gazi Üniversitesi.
- Özmen, E. R. (2012), *Öğretim Stratejileri*, E. R. Özmen (Ed.), *Zihinsel Engellilerde Öğretmenlik Uygulaması (Öğrencilikten Öğretmenliğe Geçiş Süreci)*, (sf. 227-268) Ankara: Pegem Yayınevi.
- Spelling and Writing for Beginners*, (2010), North Carolina: Carson Dellosa Education.
- Team, S., (2012), *Page Per Day Reading Skills*, New York: Random House.
- Yağcı, B., (2017), *Okuma Yazma Öğreniyorum Seti*, İstanbul: Bilfen Yayıncılık.

Görsel Kaynakça

Aşağıda numarası belirtilen görseller www.shutterstock.com sitesinden 10.09.2018 tarihinde telifi ödene-
rek alınmıştır.

www.shutterstock.com ID: 1129822811
www.shutterstock.com ID: 1142863325
www.shutterstock.com ID: 734952880
www.shutterstock.com ID: 692228563
www.shutterstock.com ID: 712142761
www.shutterstock.com ID: 637776514
www.shutterstock.com ID: 708394945
www.shutterstock.com ID: 698519353
www.shutterstock.com ID: 1120457135
www.shutterstock.com ID: 1106481293
www.shutterstock.com ID: 1200428728
www.shutterstock.com ID: 1105761431
www.shutterstock.com ID: 1029932005
www.shutterstock.com ID: 1033938418
www.shutterstock.com ID: 709098922
www.shutterstock.com ID: 97568123
www.shutterstock.com ID: 1238256415
www.shutterstock.com ID: 159284957
www.shutterstock.com ID: 105257606
www.shutterstock.com ID: 301888667
www.shutterstock.com ID: 49814260

Kitapta yer alan vektörel görseller yayınevi arşivinden kullanılmıştır.



Bu kitaba sığmayan daha neler var!



Karekodla okutulan, bu kitapta
Açılı EBA ile birlikte okutulabilir!



eba
eğitim bakanlığı



**BU DERS KİTABI MİLLÎ EĞİTİM BAKANLIĞINCA
ÜCRETSİZ OLARAK VERİLMİŞTİR.
PARA İLE SATILAMAZ.**

Bandırıl Uygulamasına İlişkin Usul ve Esaslar Hakkında Yönetmeliğin Beşinci Maddesinin İkinci Fıkrası Çerçevesinde Bandrol Taahhütü Zorunlu Değildir.